

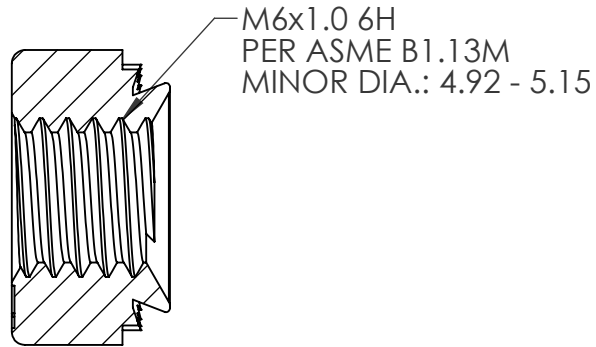

REVISIONS			
REV.	DESCRIPTION	DATE	ECN
A	INITIAL RELEASE	10/26/15	2037

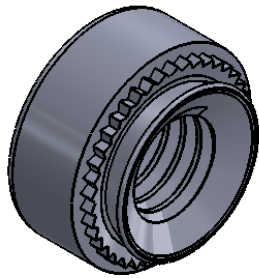
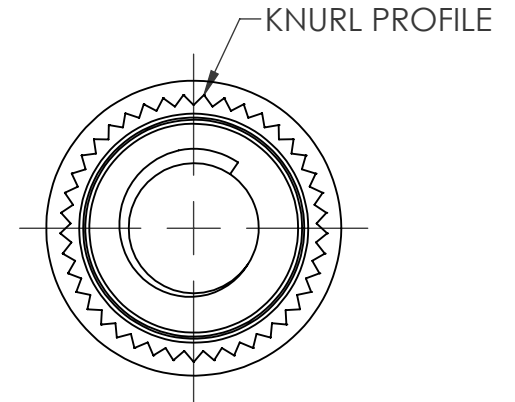
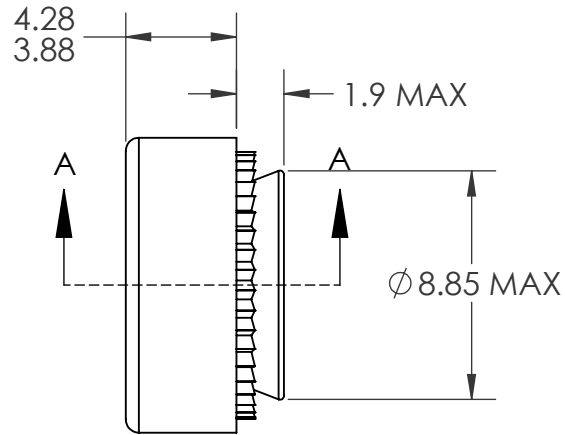
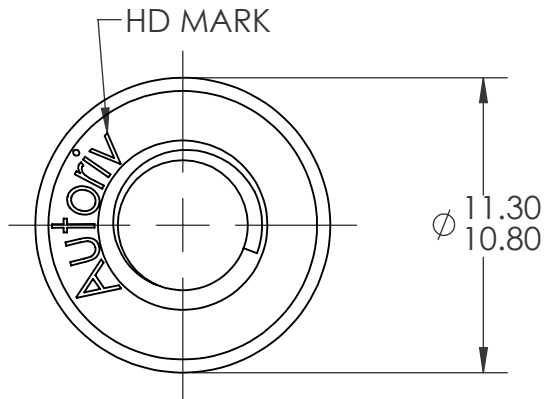

SECTION A-A
SCALE 3.5 : 1

- NOTE:
1. SHEET THICKNESS: 2.0 MIN.
 2. HOLE SIZE: $\varnothing 8.9 +0.1/-0.0$ AFTER ALL APPLIED FINISHES.
 3. CLASS 10 PROOF LOAD PER ISO 898-2.

PROPRIETARY AND CONFIDENTIAL
THIS DRAWING, AND THE INFORMATION CONTAINED HEREIN, ARE THE PROPERTY OF SHEREX AND ARE NOT TO BE USED IN ANY MANNER DETRIMENTAL TO THE INTEREST OF THE COMPANY.
SHEREX SOLUTIONS RESERVES THE RIGHT TO REVISE PART/DRAWING WITHOUT NOTICE.

		UNLESS OTHERWISE SPECIFIED:		NAME	DATE	 
		DIMENSIONS ARE IN MILLIMETERS TOLERANCES: ANGULAR: MACH ± 1 BEND ± 1 ONE PLACE DECIMAL $\pm .1$ TWO PLACE DECIMAL $\pm .05$		DRAWN	AEC	
		INTERPRET GEOMETRIC TOLERANCING PER: ASME Y14.5M-1994		CHECKED		
		MATERIAL		ENG APPR.	JVK	9/29/15
		10B21 STEEL		MFG APPR.		
		FINISH		Q.A.		
		ZINC PLATE CLEAR TRIVALENT CHROMATE PER SFS-01-001		COMMENTS:		TITLE: ASN M6 CLINCH NUT
NEXT ASSY	USED ON			E-mail: info@sherex.com www.sherex.com Phone: 866-474-3739 Fax: 716-875-0358		
APPLICATION		DO NOT SCALE DRAWING		SIZE DWG. NO. A ASN2-610-2.0		REV A
				SCALE: 2:1 WEIGHT:		SHEET 1 OF 1