

REVISIONS			
REV.	DESCRIPTION	DATE	ECN
A	INITIAL RELEASE	8/11/03	
B	NEW FINISH PER SFS-01-001, SC2	1/19/15	1739

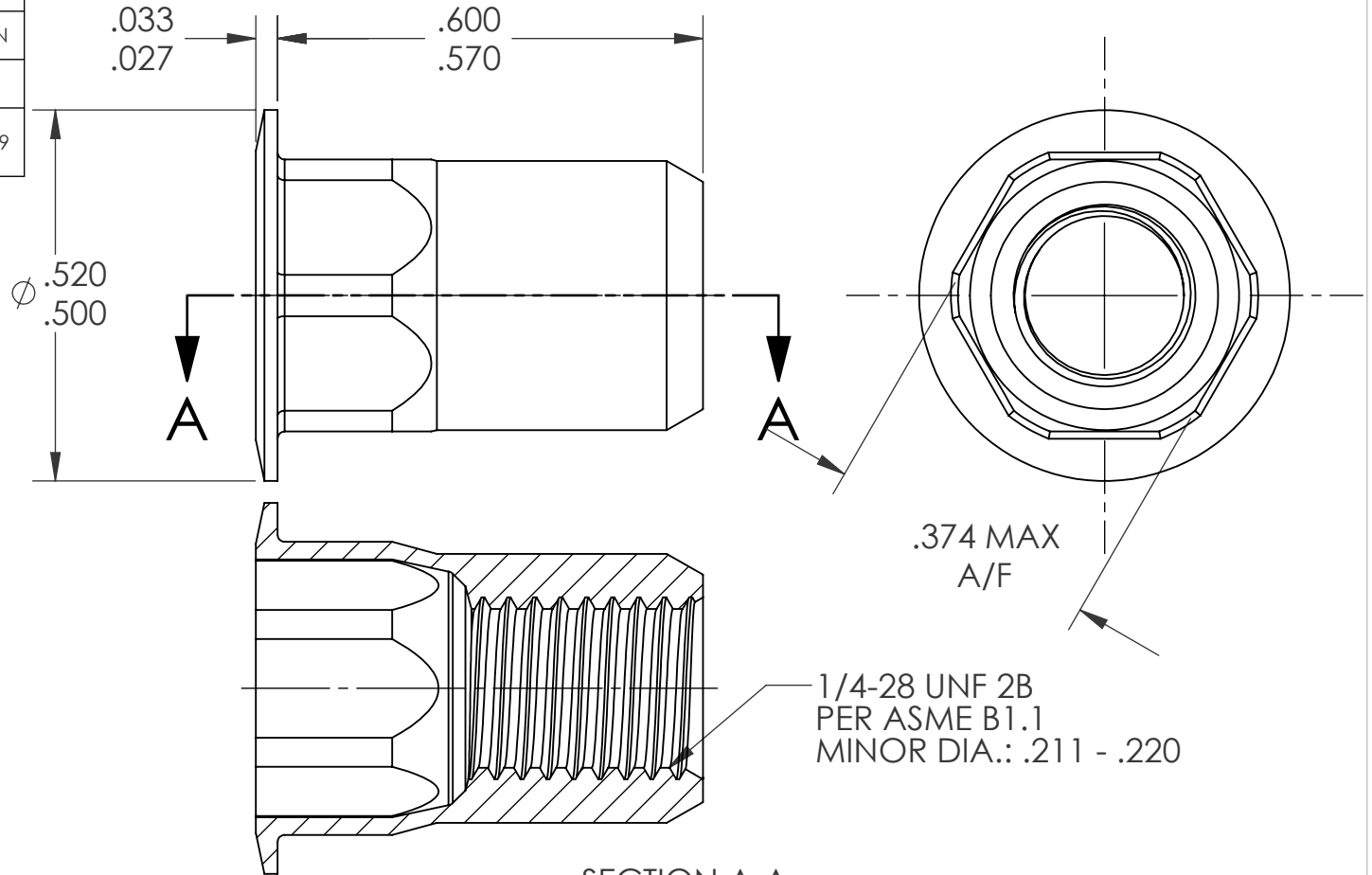
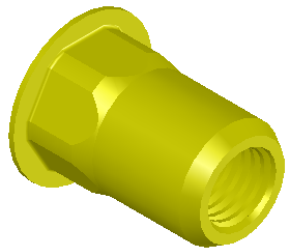

NOTE:

- GRIP RANGE: .027 - .165
- HOLE SIZE: .375 +.004/-.00 A/F AFTER ALL APPLIED FINISHES.
- INSTALLED LENGTH: .400 MAX.
- LUBRICATION: WAX
- INSTALLATION TOOL: SSG 802 SPIN SPIN

**PROPRIETARY AND CONFIDENTIAL**

THIS DRAWING, AND THE INFORMATION CONTAINED HEREIN, ARE THE PROPERTY OF SHEREX AND ARE NOT TO BE USED IN ANY MANNER DETRIMENTAL TO THE INTEREST OF THE COMPANY.  
SHEREX SOLUTIONS RESERVES THE RIGHT TO REVISE PART/DRAWING WITHOUT NOTICE.

		UNLESS OTHERWISE SPECIFIED:		NAME	DATE	
		DIMENSIONS ARE IN INCHES TOLERANCES: ANGULAR: MACH ±1 BEND ±1 TWO PLACE DECIMAL ±.01 THREE PLACE DECIMAL ±.002		DRAWN	JLA	
		INTERPRET GEOMETRIC TOLERANCING PER: ASME Y14.5M-1994		CHECKED		
		MATERIAL		ENG APPR.	JLA	8/11/03
		C1008/C1010		MFG APPR.	AJP	8/11/03
		FINISH		Q.A.		
		ZINC PLATE W/YELLOW TRIVALENT CHROMATE PER SFS-01-001, SC2		COMMENTS:		<b>TITLE:</b> LARGE FLANGE SEMI HEX OPEN END
NEXT ASSY	USED ON			E-mail: info@sherex.com www.sherex.com Phone: 866-474-3739 Fax: 716-875-0358		
APPLICATION		DO NOT SCALE DRAWING		<b>SIZE DWG. NO.</b> <b>A</b> CAH2-2528-165		<b>REV</b> <b>B</b>
				SCALE: 2:1 WEIGHT: .0039 kg		SHEET 1 OF 1