

REVISIONS			
REV.	DESCRIPTION	DATE	ECN
A	INITIAL RELEASE	8/11/03	
B	NEW FINISH PER SFS-01-001, SC2	1/21/15	1745

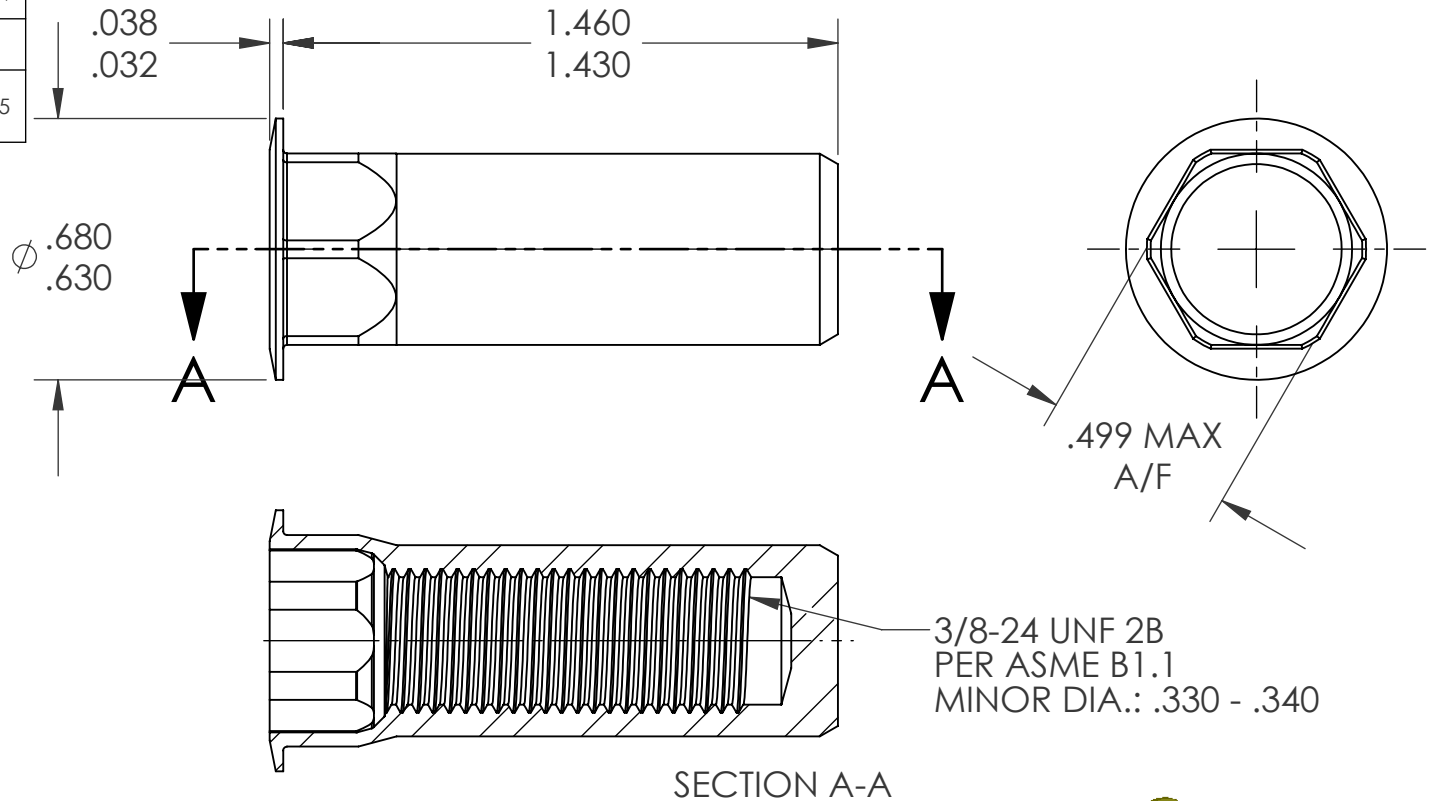

NOTE:

- GRIP RANGE: .027 - .150
- HOLE SIZE: .500 +.004/-.000 A/F AFTER ALL APPLIED FINISHES.
- INSTALLED LENGTH: 1.235 MAX.
- INSTALLED THREAD DEPTH: 1.045 REF.
- LUBRICATION: OIL
- INSTALLATION TOOL: SSG 803 SPIN SPIN

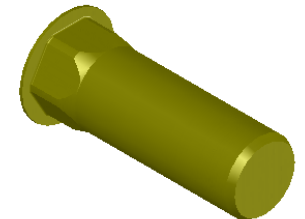

PROPRIETARY AND CONFIDENTIAL

THIS DRAWING, AND THE INFORMATION CONTAINED HEREIN, ARE THE PROPERTY OF SHEREX AND ARE NOT TO BE USED IN ANY MANNER DETRIMENTAL TO THE INTEREST OF THE COMPANY.
SHEREX SOLUTIONS RESERVES THE RIGHT TO REVISE PART/DRAWING WITHOUT NOTICE.

		UNLESS OTHERWISE SPECIFIED:	NAME	DATE	
		DIMENSIONS ARE IN INCHES TOLERANCES: ANGULAR: MACH ± 1 BEND ± 1 TWO PLACE DECIMAL ± .01 THREE PLACE DECIMAL ± .002	DRAWN	JLA	
		INTERPRET GEOMETRIC TOLERANCING PER: ASME Y14.5M-1994	CHECKED		
		MATERIAL	ENG APPR.	JLA	8/11/03
		C1008/C1010	MFG APPR.	AJP	8/11/03
		FINISH	Q.A.		
		ZINC PLATE W/YELLOW TRIVALENT CHROMATE PER SFS-01-001, SC2	COMMENTS:	TITLE: HALF HEX LARGE FLANGE CLOSED END	
NEXT ASSY	USED ON		E-mail: info@sherex.com	SIZE DWG. NO.	REV
			www.sherex.com	A CAH2-3724-150B	B
			Phone: 866-474-3739	SCALE: 2:1	WEIGHT: .0190 kg
			Fax: 716-875-0358	SHEET 1 OF 1	
	APPLICATION	DO NOT SCALE DRAWING			