

| REVISIONS |                                |         |      |
|-----------|--------------------------------|---------|------|
| REV.      | DESCRIPTION                    | DATE    | ECN  |
| A         | INITIAL RELEASE                | 8/11/03 |      |
| B         | NEW FINISH PER SFS-01-001, SC2 | 1/21/15 | 1745 |

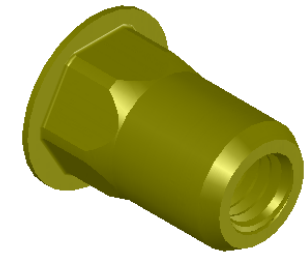
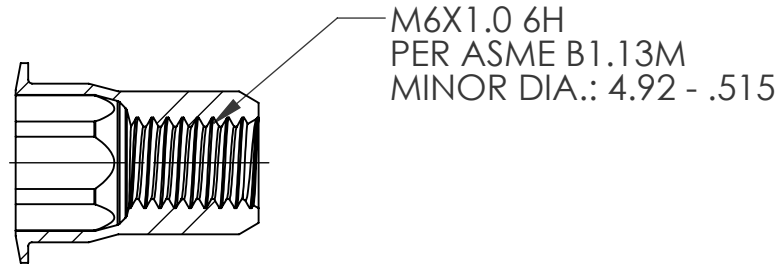
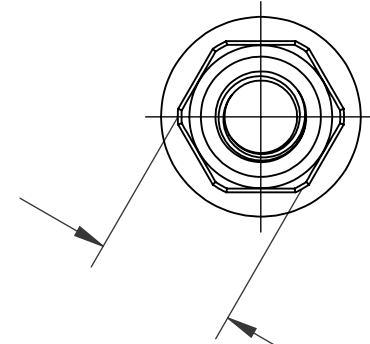

SECTION A-A  
SCALE 2 : 1

- NOTE:
- GRIP RANGE: 0.7 - 4.2
  - HOLE SIZE: 9.53 +0.1/-0.0 A/F AFTER ALL APPLIED FINISHES.
  - INSTALLED LENGTH: 10.16 MAX.
  - LUBRICATION: WAX
  - INSTALLATION TOOL: SSG 802 SPIN SPIN

**PROPRIETARY AND CONFIDENTIAL**  
THIS DRAWING, AND THE INFORMATION CONTAINED HEREIN, ARE THE PROPERTY OF SHEREX AND ARE NOT TO BE USED IN ANY MANNER DETRIMENTAL TO THE INTEREST OF THE COMPANY.  
SHEREX SOLUTIONS RESERVES THE RIGHT TO REVISE PART/DRAWING WITHOUT NOTICE.

|             |         |  |                         |             |
|-------------|---------|--|-------------------------|-------------|
|             |         | UNLESS OTHERWISE SPECIFIED:  | NAME                    | DATE        |
|             |         | DIMENSIONS ARE IN MILLIMETERS<br>TOLERANCES:<br>ANGULAR: MACH ± 1 BEND ± 1<br>ONE PLACE DECIMAL ± 0.10<br>TWO PLACE DECIMAL ± 0.05 | DRAWN                   | JLA 8/11/03 |
|             |         | INTERPRET GEOMETRIC TOLERANCING PER: ASME Y14.5M-1994  | CHECKED                 |             |
|             |         | MATERIAL   | ENG APPR.               | JLA 8/11/03 |
|             |         | C1008/C1010  | MFG APPR.               | AJP 8/11/03 |
|             |         | FINISH   | Q.A.                    |             |
|             |         | ZINC PLATE W/YELLOW TRIVALENT CHROMATE PER SFS-01-001, SC2   | COMMENTS:               |             |
| NEXT ASSY   | USED ON |  | E-mail: info@sherex.com |             |
|             |         |  | www.sherex.com          |             |
|             |         |  | Phone: 866-474-3739     |             |
|             |         |  | Fax: 716-875-0358       |             |
| APPLICATION |         | DO NOT SCALE DRAWING   |                         |             |

|   |                  |              |
|---|------------------|--------------|
|  |                  |              |
| TITLE:  |                  |              |
| LARGE FLANGE SEMI HEX   |                  |              |
| SIZE DWG. NO.   | REV              |              |
| <b>A</b> CAH2-610-4.2   | B                |              |
| SCALE: 2:1  | WEIGHT: .0047 kg | SHEET 1 OF 1 |