

REVISIONS			
REV.	DESCRIPTION	DATE	ECN
A	INITIAL RELEASE	5/23/05	
B	NEW FINISH PER SFS-01-001, SC2	1/16/15	1737

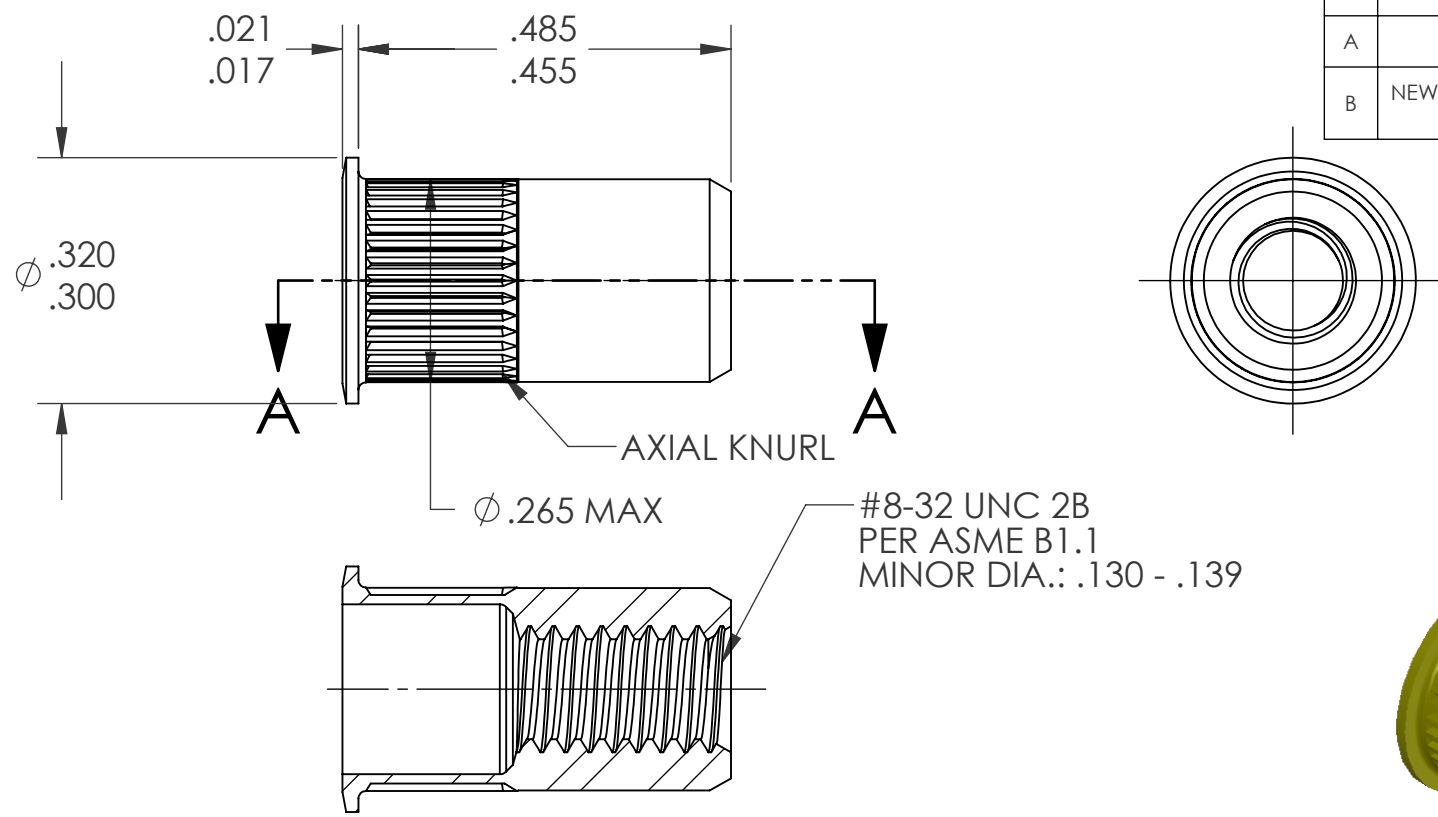

- NOTE:
- GRIP RANGE: .080 - .130
  - HOLE SIZE: .266 +.006/-.000 AFTER ALL APPLIED FINISHES.
  - INSTALLED LENGTH: .305 MAX.
  - LUBRICATION: WAX
  - INSTALLATION TOOL: SSG 801 SPIN SPIN

SECTION A-A

**PROPRIETARY AND CONFIDENTIAL**  
 THIS DRAWING, AND THE INFORMATION CONTAINED HEREIN, ARE THE PROPERTY OF SHEREX AND ARE NOT TO BE USED IN ANY MANNER DETRIMENTAL TO THE INTEREST OF THE COMPANY.  
 SHEREX SOLUTIONS RESERVES THE RIGHT TO REVISE PART/DRAWING WITHOUT NOTICE.

		UNLESS OTHERWISE SPECIFIED:		NAME	DATE
		DIMENSIONS ARE IN INCHES TOLERANCES: ANGULAR: MACH ±1 BEND ±1 TWO PLACE DECIMAL ±.01 THREE PLACE DECIMAL ±.002	DRAWN	TOO	5/23/05
		INTERPRET GEOMETRIC TOLERANCING PER: ASME Y14.5M-1994	CHECKED		
		MATERIAL	ENG APPR.	TOO	5/23/05
		C1008/C1010	MFG APPR.	AJP	5/23/05
		FINISH	Q.A.		
		ZINC PLATE W/YELLOW TRIVALENT CHROMATE PER SFS-01-001, SC2	COMMENTS:	E-mail: info@sherex.com www.sherex.com Phone: 866-474-3739 Fax: 716-875-0358	
NEXT ASSY	USED ON				
APPLICATION		DO NOT SCALE DRAWING			

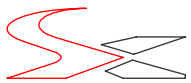

**TITLE:**  
SMALL FLANGE OPEN END

SIZE DWG. NO.	REV
<b>A</b> CAK2-0832-130	<b>B</b>

SCALE: 2:1 WEIGHT: .0018 kg SHEET 1 OF 1