

SECTION A-A

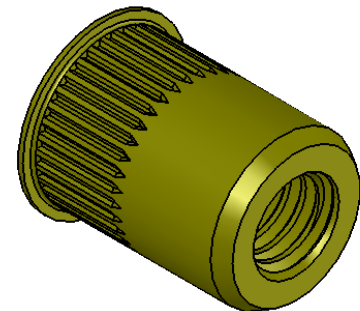

REVISIONS			
REV.	DESCRIPTION	DATE	ECN
A	INITIAL RELEASE	5/23/05	
B	NEW FINISH PER SFS-01-001, SC2	1/16/15	1737

- NOTE:
- GRIP RANGE: .027-.150
 - HOLE SIZE: .531 +.006/-.000 AFTER ALL APPLIED FINISHES.
 - INSTALLED LENGTH: .470 MAX
 - LUBRICATION: WAX
 - INSTALLATION TOOL: SSG 803 SPIN SPIN

PROPRIETARY AND CONFIDENTIAL
 THIS DRAWING, AND THE INFORMATION CONTAINED HERIN, ARE THE PROPERTY OF SHEREX AND ARE NOT TO BE USED IN ANY MANNER DETRIMENT TO THE INTEREST OF THE COMPANY.
 SHEREX RESERVES THE RIGHT TO REVISE PART/DRAWING WITHOUT NOTICE.

		UNLESS OTHERWISE SPECIFIED: DIMENSIONS ARE IN INCHES TOLERANCES: ANGULAR: MACH ±1 BEND ±1 TWO PLACE DECIMAL ±.01 THREE PLACE DECIMAL ±.005 INTERPRET GEOMETRIC TOLERANCING PER: ASME Y14.5M-1994		NAME	DATE
		MATERIAL C1008/C1010		TOO	5/23/05
		FINISH ZINC PLATE W/YELLOW TRIVALENT CHROMATE PER SFS-01-001, SC2		CHECKED	
				ENG APPR.	TOO 5/23/05
				MFG APPR.	AJP 5/23/05
				Q.A.	
				COMMENTS: E-mail: info@sherex.com www.sherex.com Phone: 866-474-3739 Fax: 716-875-0358	
NEXT ASSY	USED ON				
APPLICATION		DO NOT SCALE DRAWING			

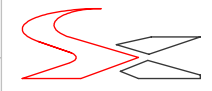

TITLE:
SMALL FLANGE OPEN END

SIZE A	DWG. NO. CAK2-3118-150	REV B
SCALE: 2:1	WEIGHT: .0099 kg	SHEET 1 OF 1