

REVISIONS			
REV.	DESCRIPTION	DATE	ECN
A	INITIAL RELEASE	7/20/05	
B	NEW FINISH PER SFS-01-001, SC2	1/14/15	1735

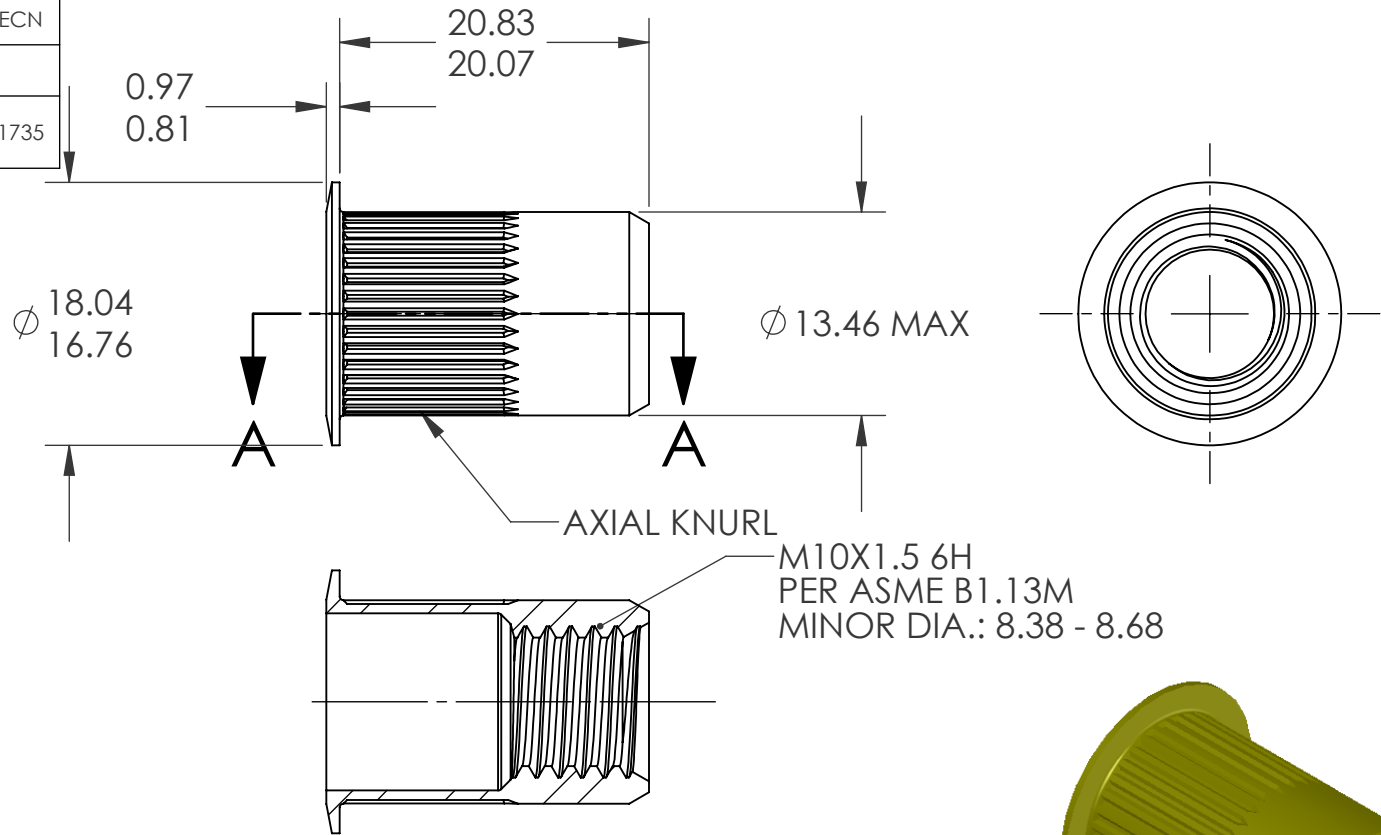

NOTE:

- GRIP RANGE: 3.8 - 7.9
- HOLE SIZE: 13.50 +0.15/-0.0 AFTER ALL APPLIED FINISHES.
- INSTALLED LENGTH: 10.80 MAX.
- LUBRICATION: WAX
- INSTALLATION TOOL: SSG 803 SPIN SPIN

SECTION A-A

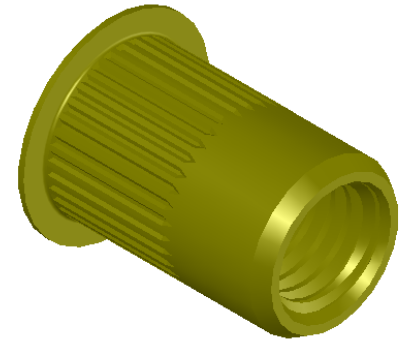

PROPRIETARY AND CONFIDENTIAL

THIS DRAWING, AND THE INFORMATION CONTAINED HEREIN, ARE THE PROPERTY OF SHEREX AND ARE NOT TO BE USED IN ANY MANNER DETRIMENTAL TO THE INTEREST OF THE COMPANY.
SHEREX SOLUTIONS RESERVES THE RIGHT TO REVISE PART/DRAWING WITHOUT NOTICE.

		UNLESS OTHERWISE SPECIFIED:	NAME	DATE
		DIMENSIONS ARE IN MILLIMETERS TOLERANCES: ANGULAR: MACH ± 1 BEND ± 1 ONE PLACE DECIMAL ± 0.10 TWO PLACE DECIMAL ± 0.05	DRAWN	TOO 7/20/05
		INTERPRET GEOMETRIC TOLERANCING PER: ASME Y14.5M-1994	CHECKED	
		MATERIAL	ENG APPR.	TOO 7/20/05
		C1008/1010	MFG APPR.	AJP 7/20/05
		FINISH	Q.A.	
		ZINC PLATE W/YELLOW TRIVALENT CHROMATE PER SFS-01-001, SC2	COMMENTS:	
NEXT ASSY	USED ON		E-mail: info@sherex.com	
			www.sherex.com	
			Phone: 866-474-3739	
			Fax: 716-875-0358	
	APPLICATION	DO NOT SCALE DRAWING		



TITLE:

LARGE FLANGE OPEN END

SIZE DWG. NO.

A CAL2-1015-7.9

REV

B

SCALE: 2:1 WEIGHT: .0088 kg

SHEET 1 OF 1