

REVISIONS			
REV.	DESCRIPTION	DATE	ECN
A	INITIAL RELEASE	5/23/05	
B	NEW FINISH PER SFS-01-001, SC2	1/16/15	1737

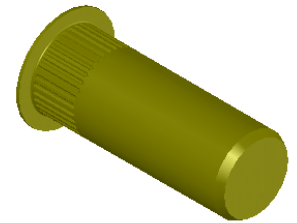
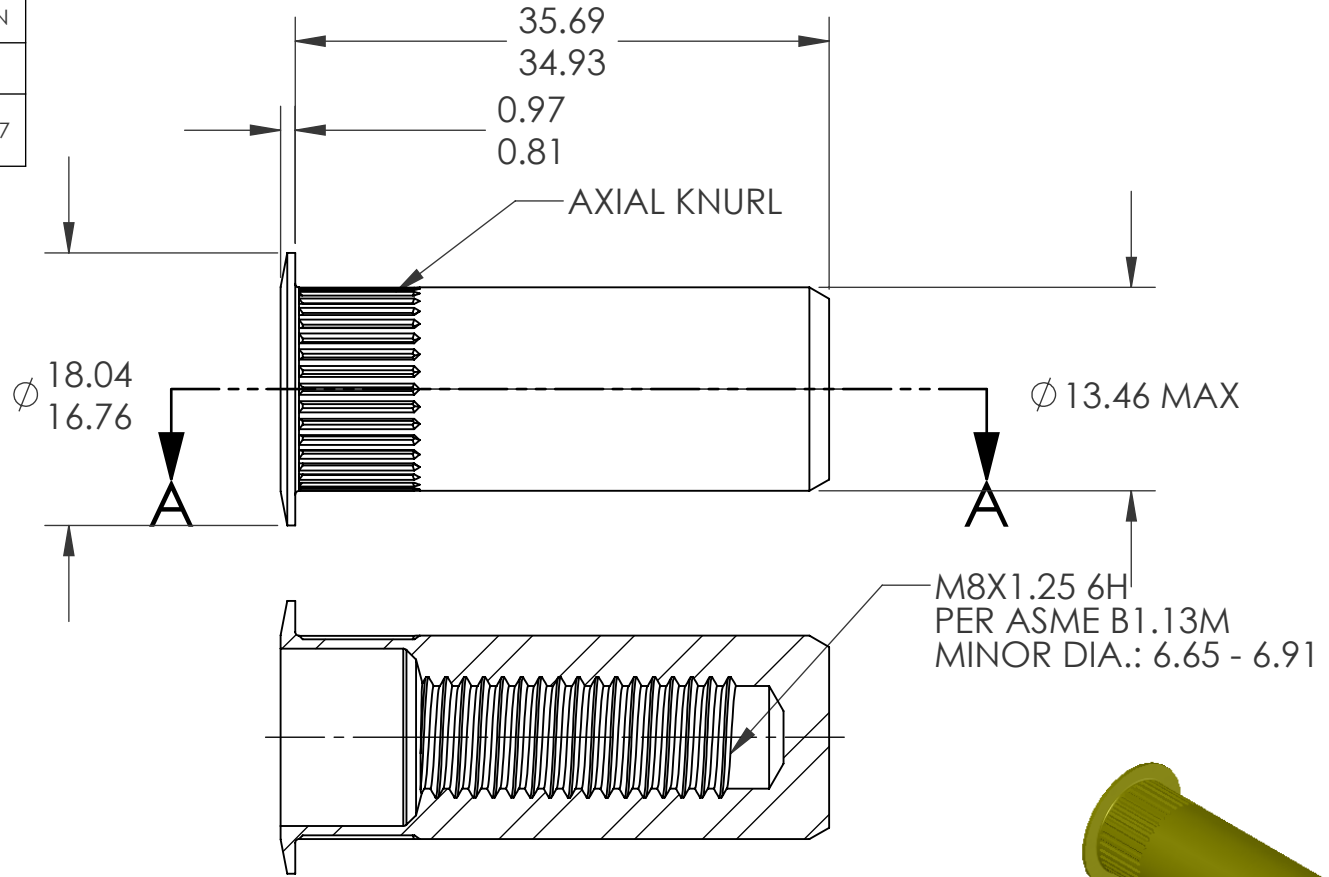
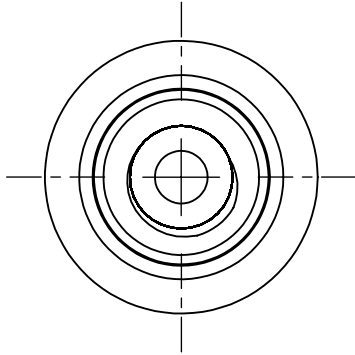

**NOTE:**

- GRIP RANGE: 0.70 - 3.80
- HOLE SIZE: 13.50 +0.15/-0.0 AFTER ALL APPLIED FINISHES.
- INSTALLED LENGTH: 29.85 MAX.
- INSTALLED THREAD DEPTH: 25.27 REF.
- LUBRICATION: OIL
- INSTALLATION TOOL: SSG 803 SPIN SPIN

SECTION A-A  
SCALE 2 : 1

**PROPRIETARY AND CONFIDENTIAL**  
THIS DRAWING, AND THE INFORMATION CONTAINED HEREIN, ARE THE PROPERTY OF SHEREX AND ARE NOT TO BE USED IN ANY MANNER DETRIMENTAL TO THE INTEREST OF THE COMPANY.  
SHEREX SOLUTIONS RESERVES THE RIGHT TO REVISE PART/DRAWING WITHOUT NOTICE.

		UNLESS OTHERWISE SPECIFIED:		NAME	DATE
		DIMENSIONS ARE IN MILLIMETERS TOLERANCES: ANGULAR: MACH ± 1 BEND ± 1 ONE PLACE DECIMAL ± 0.10 TWO PLACE DECIMAL ± 0.05	DRAWN	TOO	5/23/05
		INTERPRET GEOMETRIC TOLERANCING PER: ASME Y14.5M-1994	CHECKED		
		MATERIAL C1008/C1010	ENG APPR.	TOO	5/23/05
		FINISH ZINC PLATE W/YELLOW TRIVALENT CHROMATE PER SFS-01-001, SC2	MFG APPR.	AJP	5/23/05
NEXT ASSY	USED ON		Q.A.		
	APPLICATION	DO NOT SCALE DRAWING	COMMENTS:	E-mail: info@sherex.com www.sherex.com Phone: 866-474-3739 Fax: 716-875-0358	

		
TITLE: LARGE FLANGE CLOSED END		
SIZE DWG. NO.		REV
<b>A</b>	CAL2-8125-3.8B	B
SCALE: 2:1	WEIGHT: .0256 kg	SHEET 1 OF 1