

REVISIONS			
REV.	DESCRIPTION	DATE	ECN
A	INITIAL RELEASE	5/8/09	1179

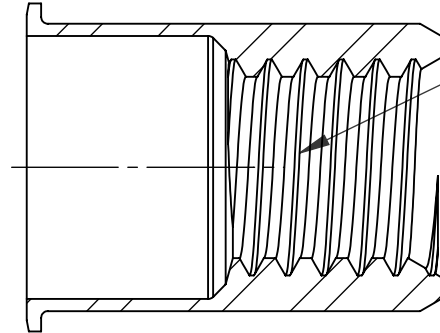
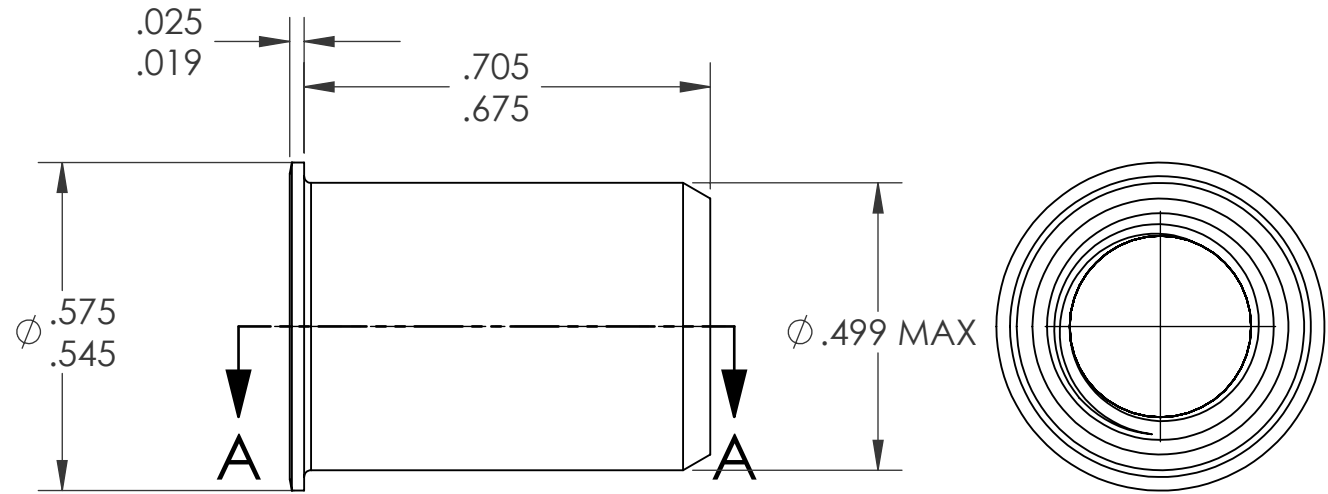
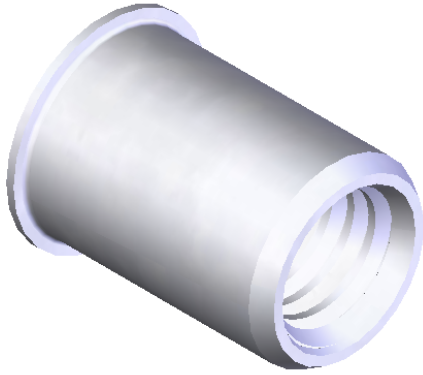

3/8-16 UNC 2B
PER ASME B1.1
MINOR DIA.: .307-.321

SECTION A-A
SCALE 3 : 1

NOTE:

- GRIP RANGE: .040 - .200
- HOLE SIZE: .500 +.006/-0.000 AFTER ALL APPLIED FINISHES.
- INSTALLED LENGTH: .540 MAX.
- LUBRICATION: WAX
- INSTALLATION TOOL: SSG 803 SPIN SPIN

PROPRIETARY AND CONFIDENTIAL

THIS DRAWING, AND THE INFORMATION CONTAINED HEREIN, ARE THE PROPERTY OF SHEREX AND ARE NOT TO BE USED IN ANY MANNER DETRIMENTAL TO THE INTEREST OF THE COMPANY.
SHEREX SOLUTIONS RESERVES THE RIGHT TO REVISE PART/DRAWING WITHOUT NOTICE.

		UNLESS OTHERWISE SPECIFIED:		NAME	DATE	 <p>TITLE: SMALL FLANGE SMOOTH BODY</p>			
		DIMENSIONS ARE IN INCHES TOLERANCES: ANGULAR: MACH ±1 BEND ±1 TWO PLACE DECIMAL ±.01 THREE PLACE DECIMAL ±.002		DRAWN	TWR			5/8/09	
		INTERPRET GEOMETRIC TOLERANCING PER: ASME Y14.5M-1994		CHECKED					
		MATERIAL		ENG APPR.	JVK			5/8/09	
		5056 ALUMINUM		MFG APPR.					
		FINISH		Q.A.	JVK	5/8/09	SIZE DWG. NO.	REV	
NEXT ASSY		USED ON		COMMENTS:		A CAO3-3716-200		A	
		DO NOT SCALE DRAWING		E-mail: info@sherex.com www.sherex.com Phone: 866-474-3739 Fax: 716-875-0358		SCALE: 2:1		WEIGHT: kg	SHEET 1 OF 1