

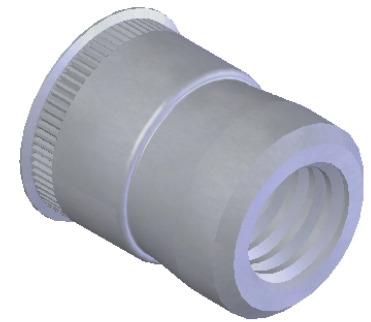

SECTION A-A

NOTE:

1. GRIP RANGE: .030 MIN.
2. HOLE SIZE:
 1. .030 - .090 MT'L THICK.: .2812 AFTER ALL APPLIED FINISHES.
 2. .091 - .124 MT'L THICK.: .2900 AFTER ALL APPLIED FINISHES.
 3. .125 - .186 MT'L THICK.: .2900 AFTER ALL APPLIED FINISHES.
 4. .187 - OVER MT'L THICK.: .2969 AFTER ALL APPLIED FINISHES.
3. INSTALLED LENGTH: N/A
4. LUBRICATION:
5. INSTALLATION TOOL: SSG 802 SPIN SPIN



PROPRIETARY AND CONFIDENTIAL
 THIS DRAWING, AND THE INFORMATION CONTAINED HEREIN, ARE THE PROPERTY OF SHEREX AND ARE NOT TO BE USED IN ANY MANNER DETRIMENTAL TO THE INTEREST OF THE COMPANY.
 SHEREX SOLUTIONS RESERVES THE RIGHT TO REVISE PART/DRAWING WITHOUT NOTICE.

		UNLESS OTHERWISE SPECIFIED:		NAME	DATE	
		DIMENSIONS ARE IN INCHES TOLERANCES: ANGULAR: MACH ±1 BEND ±1 TWO PLACE DECIMAL ±.01 THREE PLACE DECIMAL ±.002		DRAWN	JLA	
		INTERPRET GEOMETRIC TOLERANCING PER: ASME Y14.5M-1994		CHECKED		
		MATERIAL		ENG APPR.	JLA	8/11/03
		12L14		MFG APPR.	AJP	8/11/03
		FINISH		Q.A.		
		CADMIUM PER QQ-P-416 TYPE I CLASS 3		COMMENTS:		TITLE: SMALL FLANGE SWAGING
NEXT ASSY	USED ON			E-mail: info@sherex.com www.sherex.com Phone: 866-474-3739 Fax: 716-875-0358		
APPLICATION		DO NOT SCALE DRAWING				SIZE DWG. NO. REV A CAT2-1032 A
				SCALE: 2:1 WEIGHT: .0010 kg SHEET 1 OF 1		