

REVISIONS			
REV.	DESCRIPTION	DATE	ECN
A	INITIAL RELEASE	3/6/06	N/A
B	CORRECTED IL	12/10/09	1245
C	NEW FINISH PER SFS-01-001, SC2	2/27/15	1786

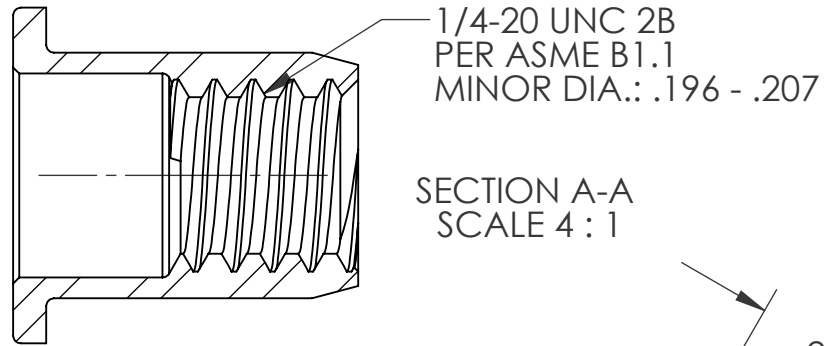

SECTION A-A
SCALE 4:1

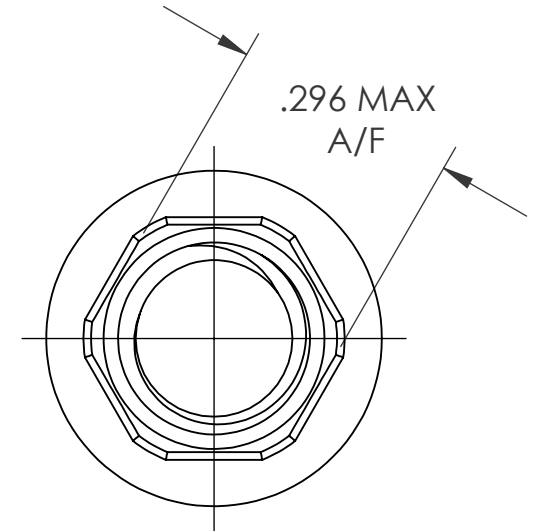
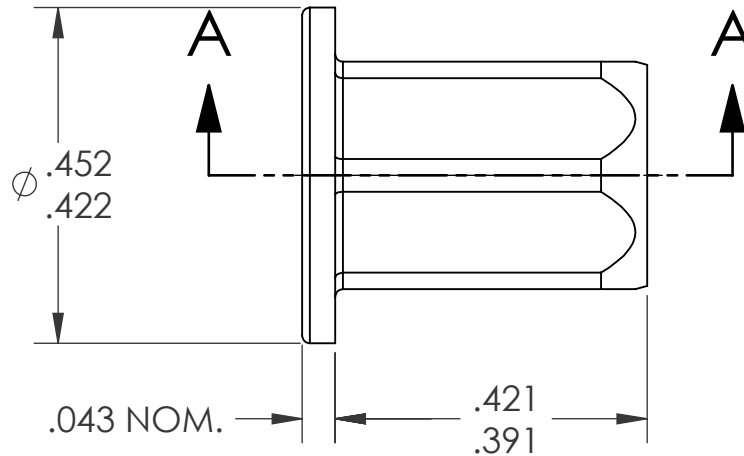

NOTE:

- GRIP RANGE: .020 - .085
- HOLE SIZE: .296 +.006/-.000 A/F AFTER ALL APPLIED FINISHES.
- INSTALLED LENGTH: .250 REF.
- LUBRICATION: NONE
- INSTALLATION TOOL: MS 50 SPIN PULL

PROPRIETARY AND CONFIDENTIAL
THIS DRAWING, AND THE INFORMATION CONTAINED HEREIN, ARE THE PROPERTY OF SHEREX AND ARE NOT TO BE USED IN ANY MANNER DETRIMENTAL TO THE INTEREST OF THE COMPANY.
SHEREX SOLUTIONS RESERVES THE RIGHT TO REVISE PART/DRAWING WITHOUT NOTICE.

		UNLESS OTHERWISE SPECIFIED:		NAME	DATE	
		DIMENSIONS ARE IN INCHES TOLERANCES: ANGULAR: MACH ±1 BEND ±1 TWO PLACE DECIMAL ±.01 THREE PLACE DECIMAL ±.002		DRAWN	TOO	
		INTERPRET GEOMETRIC TOLERANCING PER: ASME Y14.5M-1994		CHECKED		
		MATERIAL		ENG APPR.	TOO	3/6/06
		C1008/C1010		MFG APPR.	AJP	3/6/06
		FINISH		Q.A.		
		ZINC PLATE W/YELLOW TRIVALENT CHROMATE PER SFS-01-001, SC2		COMMENTS:		TITLE: FLAT HEX FULL HEX
NEXT ASSY	USED ON			E-mail: info@sherex.com www.sherex.com Phone: 866-474-3739 Fax: 716-875-0358		
APPLICATION		DO NOT SCALE DRAWING		SIZE DWG. NO. A CFH2-2520-085		REV C
				SCALE: 2:1 WEIGHT: .0020 kg		SHEET 1 OF 1