

SECTION A-A

NOTE:

1. GRIP RANGE: .030 MIN.
2. HOLE SIZE:
  1. .030 - .090 MT'L THICK.: .2812 AFTER ALL APPLIED FINISHES.
  2. .091 - .124 MT'L THICK.: .2900 AFTER ALL APPLIED FINISHES.
  3. .125 - .186 MT'L THICK.: .2900 AFTER ALL APPLIED FINISHES.
  4. .187 - OVER MT'L THICK.: .2969 AFTER ALL APPLIED FINISHES.
3. INSTALLED LENGTH: N/A
4. LUBRICATION:
5. INSTALLATION TOOL: SSG 802 SPIN SPIN

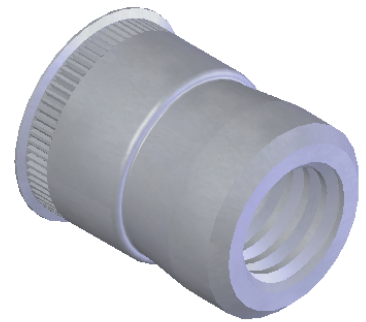

**PROPRIETARY AND CONFIDENTIAL**  
 THIS DRAWING, AND THE INFORMATION CONTAINED HEREIN, ARE THE PROPERTY OF SHEREX AND ARE NOT TO BE USED IN ANY MANNER DETRIMENTAL TO THE INTEREST OF THE COMPANY.  
 SHEREX SOLUTIONS RESERVES THE RIGHT TO REVISE PART/DRAWING WITHOUT NOTICE.

		UNLESS OTHERWISE SPECIFIED:	NAME	DATE
		DIMENSIONS ARE IN INCHES TOLERANCES: ANGULAR: MACH ±1 BEND ±1 TWO PLACE DECIMAL ±.01 THREE PLACE DECIMAL ±.002	DRAWN	JLA 8/11/03
		INTERPRET GEOMETRIC TOLERANCING PER: ASME Y14.5M-1994	CHECKED	
		MATERIAL	ENG APPR.	JLA 8/11/03
		12L14	MFG APPR.	AJP 8/11/03
		FINISH	Q.A.	
		TIN ALLOY PER ASTM B545	COMMENTS:	
NEXT ASSY	USED ON		E-mail: info@sherex.com	
			www.sherex.com	
			Phone: 866-474-3739	
			Fax: 716-875-0358	
APPLICATION		DO NOT SCALE DRAWING		

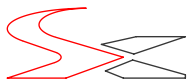
		
TITLE:		
<p style="text-align: center;"><b>CADIUM FREE SMALL FLANGE SWAGING</b></p>		
SIZE	DWG. NO.	REV
<b>A</b>	CFT2-1032	A
SCALE: 2:1	WEIGHT: .0010 kg	SHEET 1 OF 1