

REVISIONS			
REV.	DESCRIPTION	DATE	ECN
A	INITIAL RELEASE	5/18/09	1184

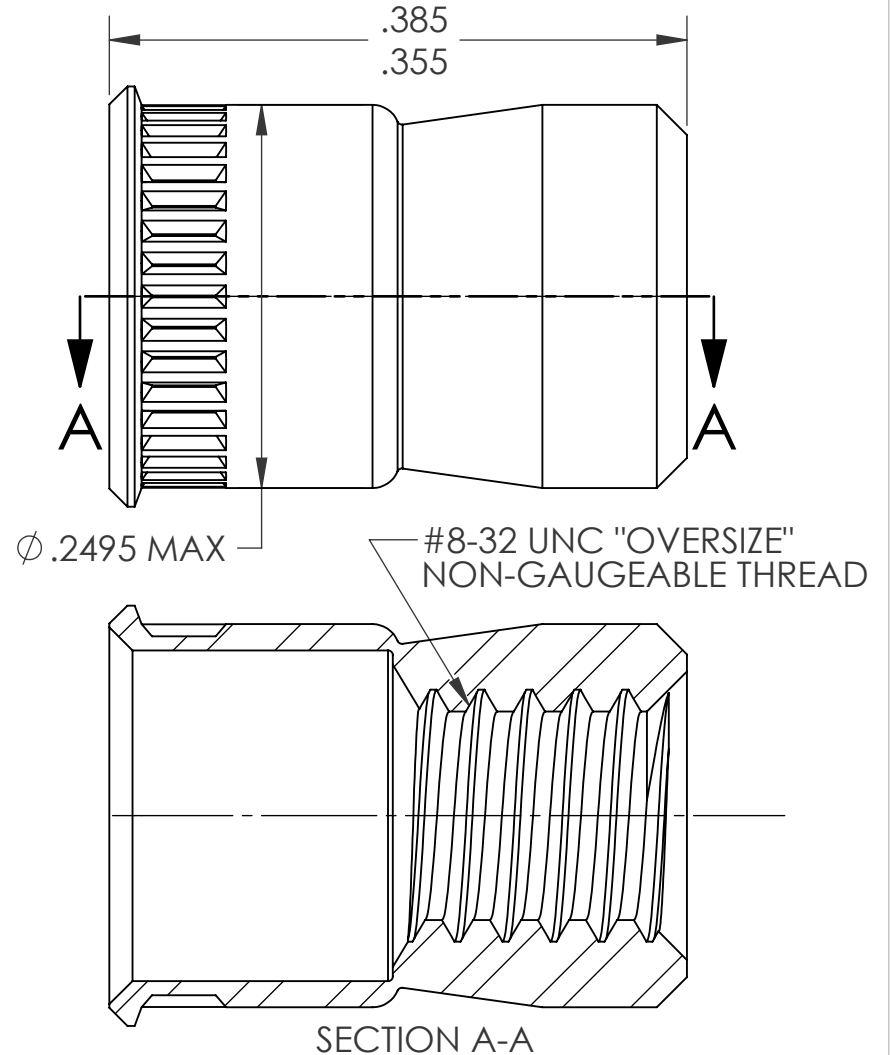
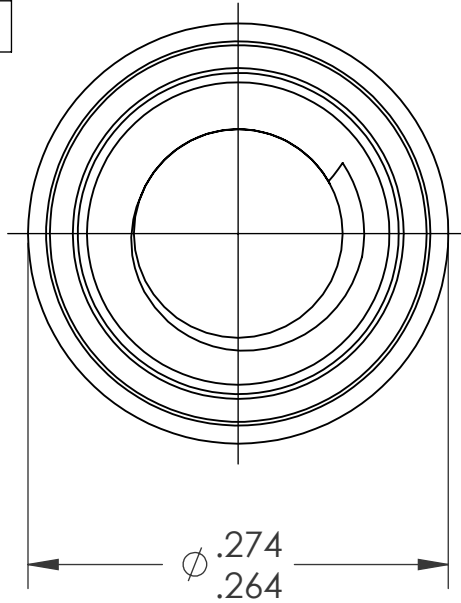
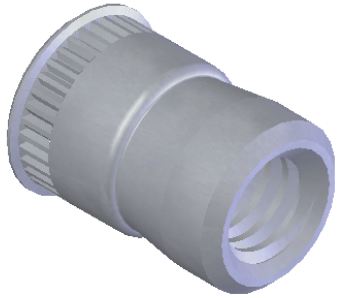

NOTE:

- GRIP RANGE: .030 MIN.
- HOLE SIZE:
 - .030 - .090 MT'L THICK.: .2500 AFTER ALL APPLIED FINISHES.
 - .091 - .124 MT'L THICK.: .2570 AFTER ALL APPLIED FINISHES.
 - .125 - .186 MT'L THICK.: .2656 AFTER ALL APPLIED FINISHES.
 - .187 - OVER MT'L THICK.: .2656 AFTER ALL APPLIED FINISHES.
- INSTALLED LENGTH: N/A
- LUBRICATION: NONE
- INSTALLATION TOOL: SSG 801 SPIN SPIN

SECTION A-A

PROPRIETARY AND CONFIDENTIAL

THIS DRAWING, AND THE INFORMATION CONTAINED HEREIN, ARE THE PROPERTY OF SHEREX AND ARE NOT TO BE USED IN ANY MANNER DETRIMENTAL TO THE INTEREST OF THE COMPANY. SHEREX SOLUTIONS RESERVES THE RIGHT TO REVISE PART/DRAWING WITHOUT NOTICE.

		UNLESS OTHERWISE SPECIFIED:		NAME	DATE
		DIMENSIONS ARE IN INCHES TOLERANCES: ANGULAR: MACH ± 1 BEND ± 1 TWO PLACE DECIMAL $\pm .01$ THREE PLACE DECIMAL $\pm .002$		DRAWN	TWR 5/18/09
		INTERPRET GEOMETRIC TOLERANCING PER: ASME Y14.5M-1994		CHECKED	
		MATERIAL		ENG APPR.	JVK 5/18/09
		6061-T6 ALUMINUM		MFG APPR.	
		FINISH		Q.A.	JVK 5/18/09
		TIN ALLOY PER ASTM B545		COMMENTS:	
NEXT ASSY	USED ON	E-mail: info@sherex.com www.sherex.com Phone: 866-474-3739 Fax: 716-875-0358			
APPLICATION		DO NOT SCALE DRAWING			



TITLE:
SMALL FLANGE SWAGING

SIZE DWG. NO. REV
A CFT3-0832 A

SCALE: 2:1 WEIGHT: kg SHEET 1 OF 1