

REVISIONS			
REV.	DESCRIPTION	DATE	ECN
A	INITIAL RELEASE	5/12/09	1182

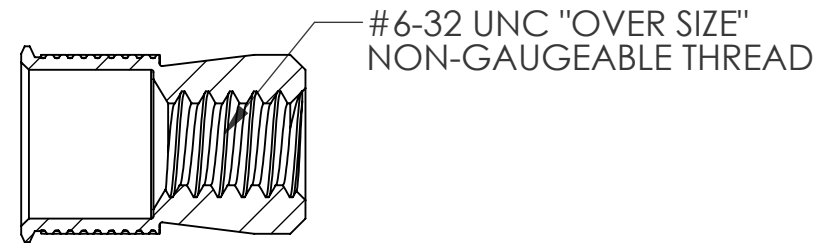
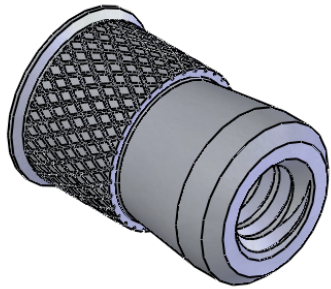
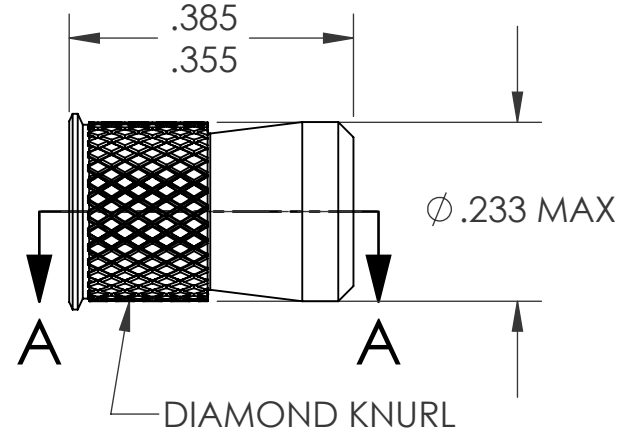
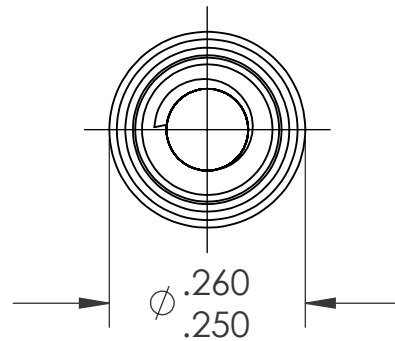

SECTION A-A
SCALE 4 : 1

NOTE:

- GRIP RANGE: .062 MIN.
- HOLE SIZE: .234 +.005/- .000 AFTER ALL APPLIED FINISHES.
- INSTALLED LENGTH: N/A
- LUBRICATION: NONE
- INSTALLATION TOOL: SSG 801 SPIN SPIN

PROPRIETARY AND CONFIDENTIAL

THIS DRAWING, AND THE INFORMATION CONTAINED HEREIN, ARE THE PROPERTY OF SHEREX AND ARE NOT TO BE USED IN ANY MANNER DETRIMENTAL TO THE INTEREST OF THE COMPANY.
SHEREX SOLUTIONS RESERVES THE RIGHT TO REVISE PART/DRAWING WITHOUT NOTICE.

		UNLESS OTHERWISE SPECIFIED:		NAME	DATE		
		DIMENSIONS ARE IN INCHES TOLERANCES: ANGULAR: MACH ± 1 BEND ± 1 TWO PLACE DECIMAL ± .01 THREE PLACE DECIMAL ± .002		DRAWN	TWR		5/12/09
		INTERPRET GEOMETRIC TOLERANCING PER: ASME Y14.5M-1994		CHECKED			
		MATERIAL		ENG APPR.	JVK		5/12/09
		6061-T6 ALUMINUM		MFG APPR.			
		FINISH		Q.A.	JVK	5/12/09	
		TIN ALLOY PER PER ASTM B545		COMMENTS:		TITLE: CADMIUM FREE KNURLED BODY SWAGING	
NEXT ASSY	USED ON			E-mail: info@sherex.com www.sherex.com Phone: 866-474-3739 Fax: 716-875-0358			
APPLICATION		DO NOT SCALE DRAWING					
				SIZE DWG. NO.	REV		
				A	CFW3-0632	A	
				SCALE: 2:1	WEIGHT: .0010 kg	SHEET 1 OF 1	