

REVISIONS			
REV.	DESCRIPTION	DATE	ECN
A	INITIAL RELEASE	5/13/09	1182

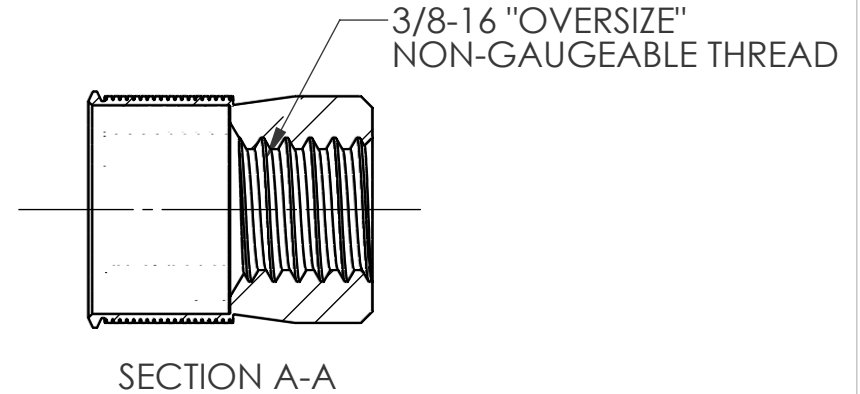
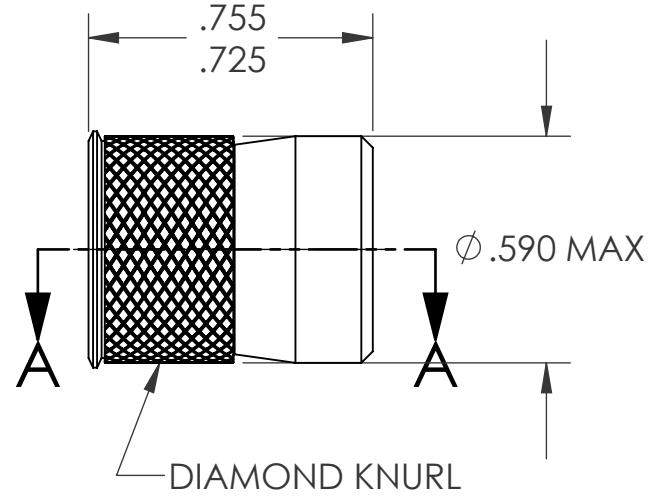
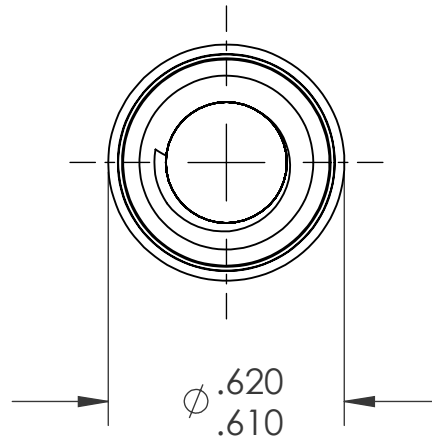
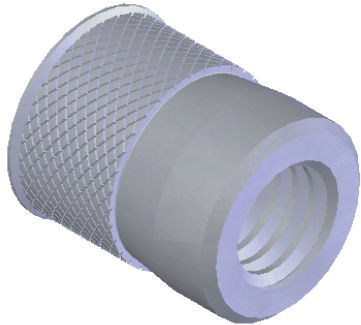

NOTE:

- GRIP RANGE: .062 MIN.
- HOLE SIZE: .594 +.005/-.000 AFTER ALL APPLIED FINISHES.
- INSTALLED LENGTH: N/A
- LUBRICATION: NONE
- INSTALLATION TOOL: SSG 803 SPIN SPIN

PROPRIETARY AND CONFIDENTIAL
 THIS DRAWING, AND THE INFORMATION CONTAINED HEREIN, ARE THE PROPERTY OF SHEREX AND ARE NOT TO BE USED IN ANY MANNER DETRIMENTAL TO THE INTEREST OF THE COMPANY.
 SHEREX SOLUTIONS RESERVES THE RIGHT TO REVISE PART/DRAWING WITHOUT NOTICE.

		UNLESS OTHERWISE SPECIFIED:		NAME	DATE		
		DIMENSIONS ARE IN INCHES TOLERANCES: ANGULAR: MACH ±1 BEND ±1 TWO PLACE DECIMAL ±.01 THREE PLACE DECIMAL ±.002		DRAWN	TWR		5/13/09
		INTERPRET GEOMETRIC TOLERANCING PER: ASME Y14.5M-1994		CHECKED			
		MATERIAL		ENG APPR.	JVK		5/13/09
		6061-T6 ALUMINUM		MFG APPR.			
		FINISH		Q.A.	JVK	5/13/09	
		TIN ALLOY PER ASTM B545		COMMENTS:		TITLE: CADMIUM FREE KNURLED BODY SWAGING	
NEXT ASSY	USED ON	DO NOT SCALE DRAWING		E-mail: info@sherex.com www.sherex.com Phone: 866-474-3739 Fax: 716-875-0358			
APPLICATION				SIZE DWG. NO. A CFW3-3716		REV A	
				SCALE: 2:1 WEIGHT: .0101 kg		SHEET 1 OF 1	