

REVISIONS			
REV.	DESCRIPTION	DATE	ECN
A	INITIAL RELEASE	10/15/14	1705

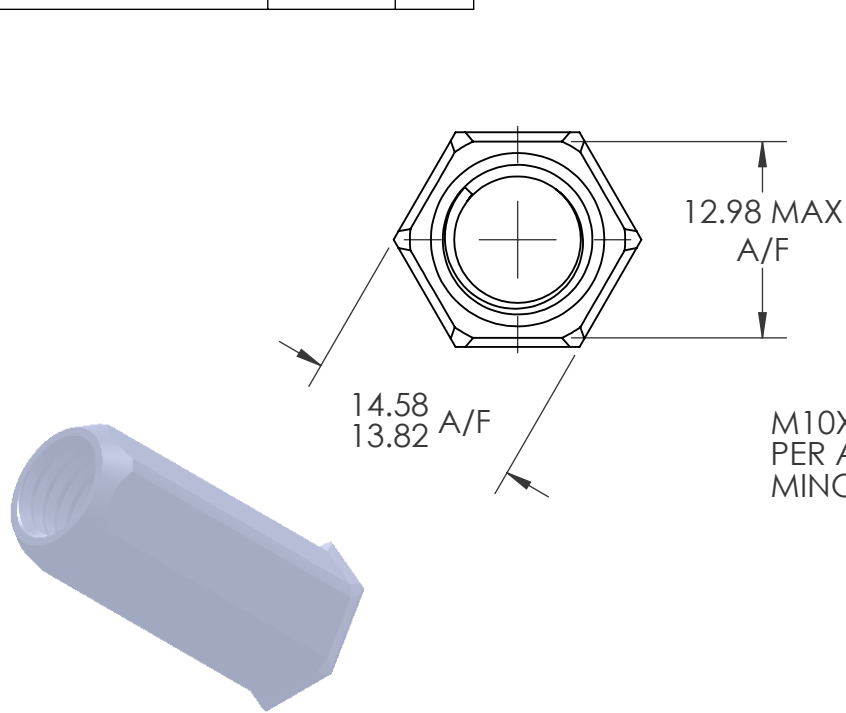

M10X1.5 6H
PER ASME B1.13M
MINOR DIA.: 8.38 - 8.68

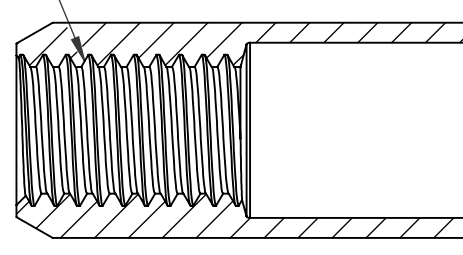
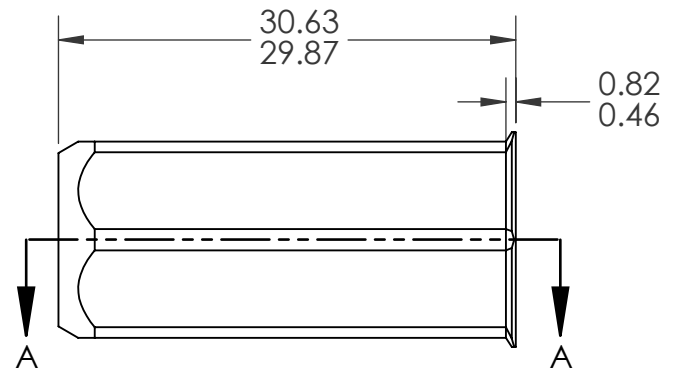

SECTION A-A

NOTE:

- GRIP RANGE: 7.5 - 10.5
- HOLE SIZE: 13.0 +0.1/-0.0 A/F AFTER ALL APPLIED FINISHES.
- INSTALLED LENGTH: 17.5 REF.
- LUBRICATION: NONE
- INSTALLATION TOOL: FLEX 5P/5S SPIN PULL
- THREAD PROOF LOAD MEETS CLASS 8 PER ISO 898-2: 50.5kN

PROPRIETARY AND CONFIDENTIAL

THIS DRAWING, AND THE INFORMATION CONTAINED HEREIN, ARE THE PROPERTY OF SHEREX AND ARE NOT TO BE USED IN ANY MANNER DETRIMENTAL TO THE INTEREST OF THE COMPANY.
SHEREX SOLUTIONS RESERVES THE RIGHT TO REVISE PART/DRAWING WITHOUT NOTICE.

		UNLESS OTHERWISE SPECIFIED:		NAME	DATE
		DIMENSIONS ARE IN MILLIMETERS TOLERANCES: ANGULAR: MACH ± 1 BEND ± 1 ONE PLACE DECIMAL ± 0.10 TWO PLACE DECIMAL ± 0.05	DRAWN	CL	10/15/14
		INTERPRET GEOMETRIC TOLERANCING PER: ASME Y14.5M-1994	CHECKED		
		MATERIAL	ENG APPR.	JVK	10/15/14
		C1008/C1010	MFG APPR.		
		FINISH	Q.A.	JR	10/15/14
		ZINC PLATE CLEAR TRIVALENT CHROMATE PER SHEREX SFS-01-001	COMMENTS:		
NEXT ASSY	USED ON		E-mail: info@sherex.com		
			www.sherex.com		
			Phone: 866-474-3739		
			Fax: 716-875-0358		
APPLICATION		DO NOT SCALE DRAWING			



TITLE:
SMALL FLANGE HEX BODY

SIZE DWG. NO. REV
A FHK2-1015-10.5 A

SCALE: 2:1 WEIGHT: kg SHEET 1 OF 1