

REVISIONS			
REV.	DESCRIPTION	DATE	ECN
A	INITIAL RELEASE	10/17/14	1707

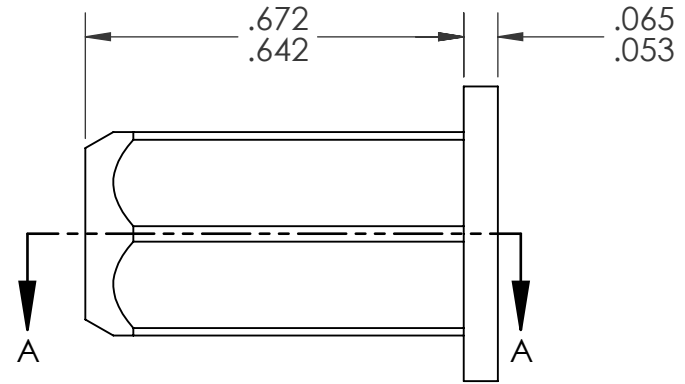

1/4-20 UNC 2B
PER ASME B1.1
MINOR DIA.: .196 - .207

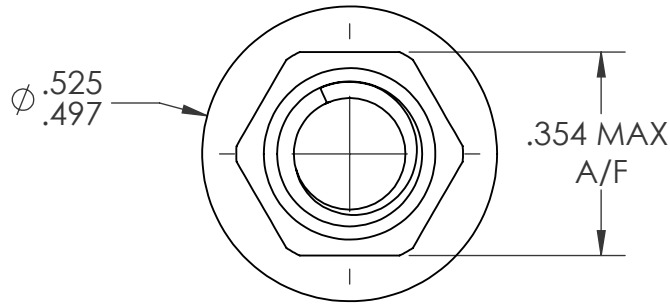
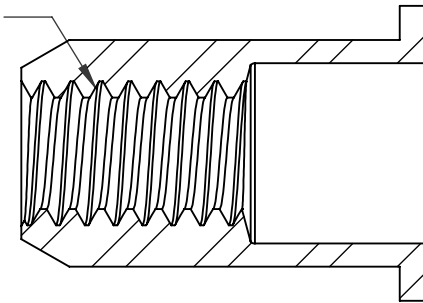

SECTION A-A
SCALE 3 : 1

NOTE:

- GRIP RANGE: .040 - .138
- HOLE SIZE: .354 +.004/-0.000 A/F AFTER ALL APPLIED FINISHES.
- INSTALLED LENGTH: .469 REF.
- LUBRICATION: NONE
- INSTALLATION TOOL: FLEX 5P/5S SPIN PULL
- THREAD PROOF LOAD MEETS GRADE 5 PER SAE J995: 4,250LBF

PROPRIETARY AND CONFIDENTIAL

THIS DRAWING, AND THE INFORMATION CONTAINED HEREIN, ARE THE PROPERTY OF SHEREX AND ARE NOT TO BE USED IN ANY MANNER DETRIMENTAL TO THE INTEREST OF THE COMPANY.
SHEREX SOLUTIONS RESERVES THE RIGHT TO REVISE PART/DRAWING WITHOUT NOTICE.

		UNLESS OTHERWISE SPECIFIED:	NAME	DATE
		DIMENSIONS ARE IN INCHES TOLERANCES: ANGULAR: MACH ± 1 BEND ± 1 TWO PLACE DECIMAL ± .01 THREE PLACE DECIMAL ± .005	DRAWN	MJK 10/17/14
		INTERPRET GEOMETRIC TOLERANCING PER: ASME Y14.5M-1994	CHECKED	
		MATERIAL	ENG APPR.	JVK 10/17/14
		C1008/C1010	MFG APPR.	
		FINISH	Q.A.	JR 10/17/14
		ZINC PLATE CLEAR TRIVALENT CHROMATE PER SHEREX SFS-01-001	COMMENTS:	
NEXT ASSY	USED ON		E-mail: info@sherex.com	
			www.sherex.com	
			Phone: 866-474-3739	
			Fax: 716-875-0358	
	APPLICATION	DO NOT SCALE DRAWING		



TITLE:

LARGE FLANGE FULL HEX

SIZE DWG. NO.

A

FHL2-2520-138

REV

A

SCALE: 2:1 WEIGHT:

SHEET 1 OF 1