

REVISIONS			
REV.	DESCRIPTION	DATE	ECN
A	INITIAL RELEASE	10/17/14	1707

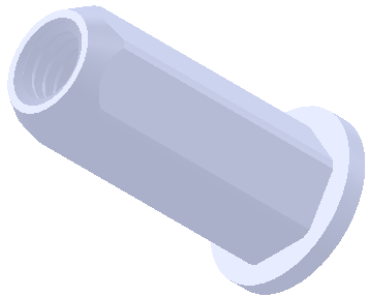

M6X1.0 6H  
PER ASME B1.13M  
MINOR DIA.: 4.92 - 5.15

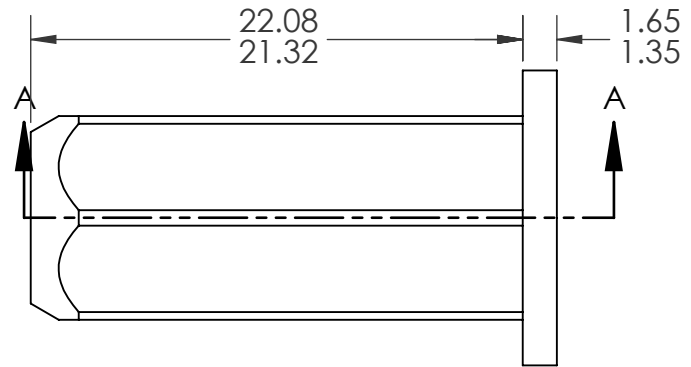
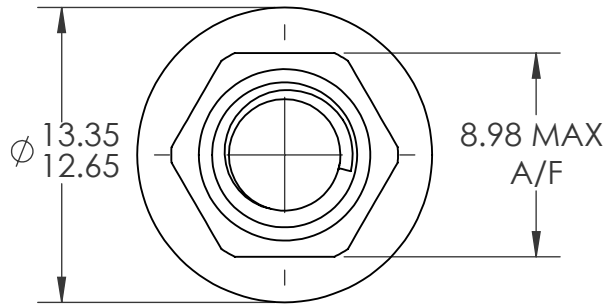
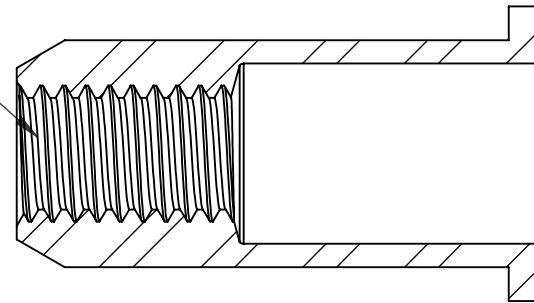

SECTION A-A  
SCALE 3 : 1

**NOTE:**

- GRIP RANGE: 6.0 - 8.5
- HOLE SIZE: 9.0 +.10/-.00 A/F AFTER ALL APPLIED FINISHES.
- INSTALLED LENGTH: 11.9 REF.
- LUBRICATION: NONE
- INSTALLATION TOOL: FLEX 5P/5S SPIN PULL
- THREAD PROOF LOAD MEETS CLASS 8 PER ISO 898-2: 17.2kN

**PROPRIETARY AND CONFIDENTIAL**  
THIS DRAWING, AND THE INFORMATION CONTAINED HEREIN, ARE THE PROPERTY OF SHEREX AND ARE NOT TO BE USED IN ANY MANNER DETRIMENTAL TO THE INTEREST OF THE COMPANY.  
SHEREX SOLUTIONS RESERVES THE RIGHT TO REVISE PART/DRAWING WITHOUT NOTICE.

		UNLESS OTHERWISE SPECIFIED:	NAME	DATE
		DIMENSIONS ARE IN MILLIMETERS TOLERANCES: ANGULAR: MACH ± 1 BEND ± 1 ONE PLACE DECIMAL ± 0.10 TWO PLACE DECIMAL ± 0.05	DRAWN	MJK 10/17/14
		INTERPRET GEOMETRIC TOLERANCING PER: ASME Y14.5M-1994	CHECKED	
		MATERIAL	ENG APPR.	JVK 10/17/14
		C1008/C1010	MFG APPR.	
		FINISH	Q.A.	JR 10/17/14
		ZINC PLATE CLEAR TRIVALENT CHROMATE PER SHEREX SFS-01-001	COMMENTS:	
NEXT ASSY	USED ON		E-mail: info@sherex.com	
			www.sherex.com	
			Phone: 866-474-3739	
			Fax: 716-875-0358	
		DO NOT SCALE DRAWING		

		
TITLE:		
LARGE FLANGE FULL HEX		
SIZE DWG. NO.	REV	
<b>A</b> FHL2-610-8.5	A	
SCALE: 2:1	WEIGHT:	SHEET 1 OF 1