

REVISIONS			
REV.	DESCRIPTION	DATE	ECN
A	INITIAL RELEASE	8/1/13	

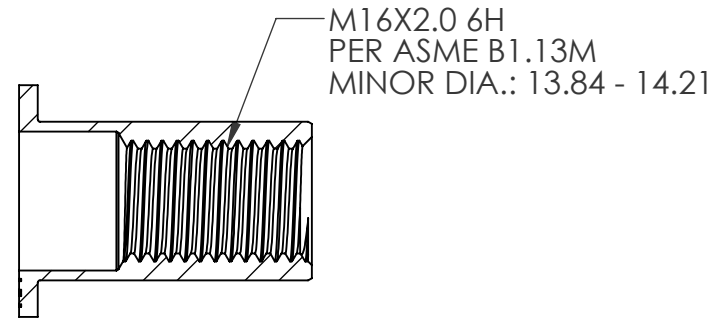
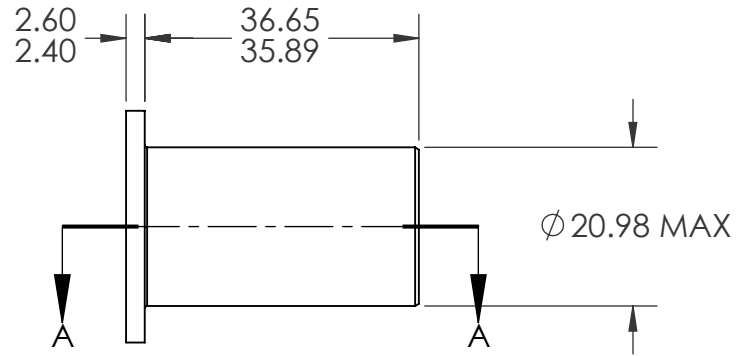
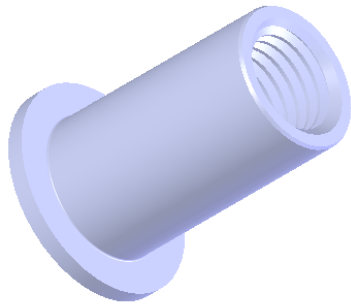
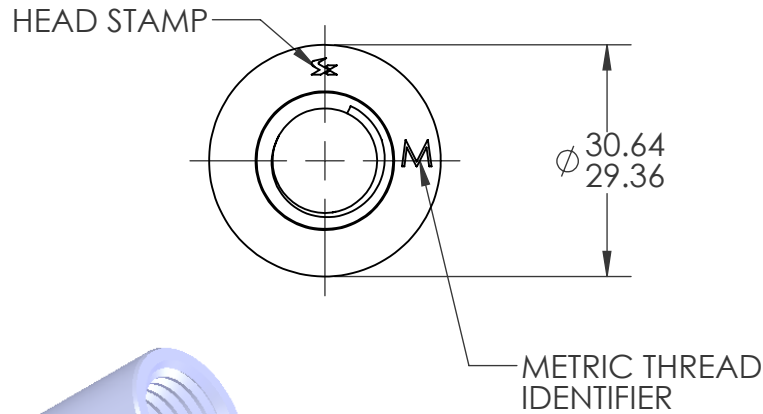

SECTION A-A

NOTE:

- GRIP RANGE: 2.00 - 5.00
- HOLE SIZE: 21.0 +.25/-0.00 AFTER ALL APPLIED FINISHES.
- INSTALLED LENGTH: 29.0 REF.
- LUBRICATION: NONE
- INSTALLATION TOOL: FLEX 18 SPIN PULL

PROPRIETARY AND CONFIDENTIAL

THIS DRAWING, AND THE INFORMATION CONTAINED HEREIN, ARE THE PROPERTY OF SHEREX AND ARE NOT TO BE USED IN ANY MANNER DETRIMENTAL TO THE INTEREST OF THE COMPANY.
SHEREX SOLUTIONS RESERVES THE RIGHT TO REVISE PART/DRAWING WITHOUT NOTICE.

		UNLESS OTHERWISE SPECIFIED:		NAME	DATE
		DIMENSIONS ARE IN MILLIMETERS TOLERANCES: ANGULAR: MACH ± 1 BEND ± 1 ONE PLACE DECIMAL ± 0.10 TWO PLACE DECIMAL ± 0.05	DRAWN	CL	8/1/13
		INTERPRET GEOMETRIC TOLERANCING PER: ASME Y14.5M-1994	CHECKED		
		MATERIAL C1010/C1022	ENG APPR.	JVK	8/1/13
		FINISH ZINC PLATE CLEAR TRIVALENT CHROMATE PER SHEREX SFS-01-001	MFG APPR.		
NEXT ASSY	USED ON		Q.A.	JVK	8/1/13
			COMMENTS:	E-mail: info@sherex.com www.sherex.com Phone: 866-474-3739 Fax: 716-875-0358	
	APPLICATION	DO NOT SCALE DRAWING			



TITLE:

LARGE THREAD ROUND BODY

SIZE DWG. NO.

A LRGR2-1620-5.0

REV

A

SCALE: 2:1 WEIGHT:

SHEET 1 OF 1