

REVISIONS			
REV.	DESCRIPTION	DATE	ECN
A	INITIAL RELEASE	8/6/13	1613

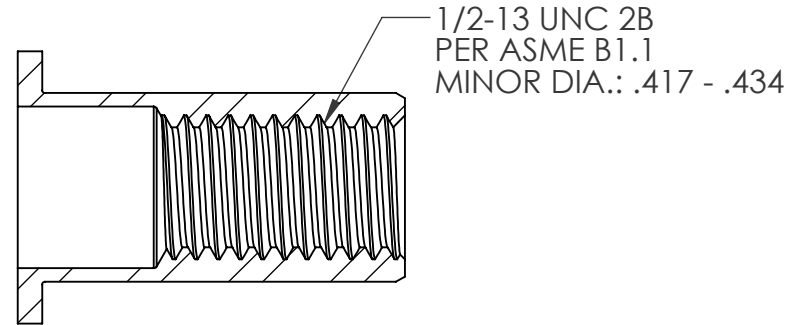
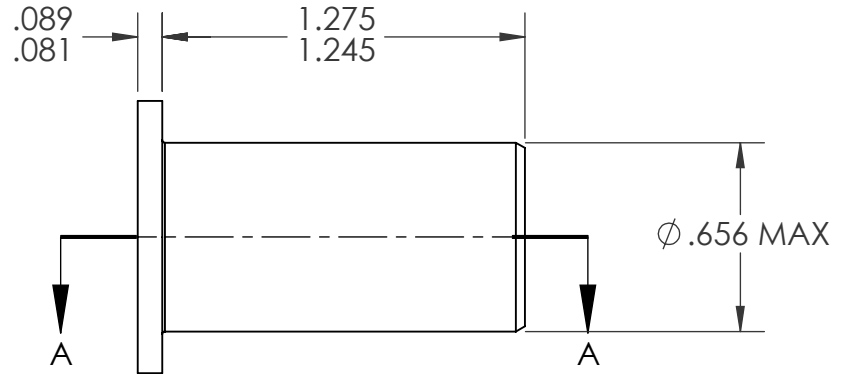
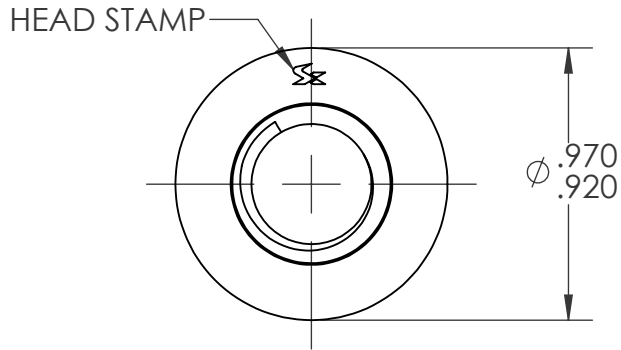

NOTE:

1. GRIP RANGE: .050 -.150
2. HOLE SIZE: .656 +.010/-0.000 AFTER ALL APPLIED FINISHES.
3. INSTALLED LENGTH: .984 REF.
4. LUBRICATION: NONE
5. INSTALLATION TOOL: FLEX 18 SPIN PULL

SECTION A-A  
SCALE 1.5 : 1

**PROPRIETARY AND CONFIDENTIAL**

THIS DRAWING, AND THE INFORMATION CONTAINED HEREIN, ARE THE PROPERTY OF SHEREX AND ARE NOT TO BE USED IN ANY MANNER DETRIMENTAL TO THE INTEREST OF THE COMPANY.  
SHEREX SOLUTIONS RESERVES THE RIGHT TO REVISE PART/DRAWING WITHOUT NOTICE.

		UNLESS OTHERWISE SPECIFIED:		NAME	DATE	
		DIMENSIONS ARE IN INCHES TOLERANCES: ANGULAR: MACH ± 1 BEND ± 1 TWO PLACE DECIMAL ± .01 THREE PLACE DECIMAL ± .005	DRAWN	CL	8/6/13	
		INTERPRET GEOMETRIC TOLERANCING PER: ASME Y14.5M-1994	CHECKED			
		MATERIAL	ENG APPR.	JVK	8/6/13	
		FINISH	MFG APPR.			
		ZINC PLATE CLEAR TRIVALENT CHROMATE PER SHEREX SFS-01-001	Q.A.	JVK	8/6/13	TITLE:
NEXT ASSY	USED ON		COMMENTS:			LARGE THREAD ROUND BODY
		APPLICATION	E-mail: info@sherex.com www.sherex.com Phone: 866-474-3739 Fax: 716-875-0358			SIZE DWG. NO.
		DO NOT SCALE DRAWING				<b>A</b> LRGR2-5013-150
						REV
						A
						SCALE: 2:1 WEIGHT: SHEET 1 OF 1