

REVISIONS				
REV.	DESCRIPTION	DATE	ECN	INITIAL
A	INITIAL RELEASE	1/21/21	3764	ARG
B	UPDATE BODY DIAMETER & GRIP RANGE	09/07/22	4105	MRA

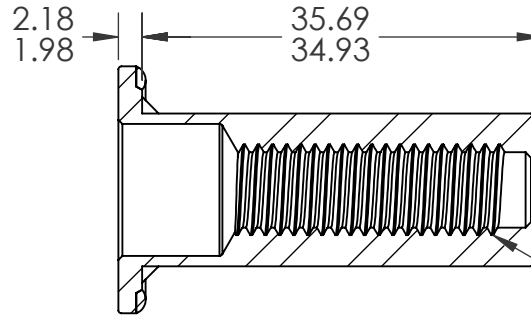
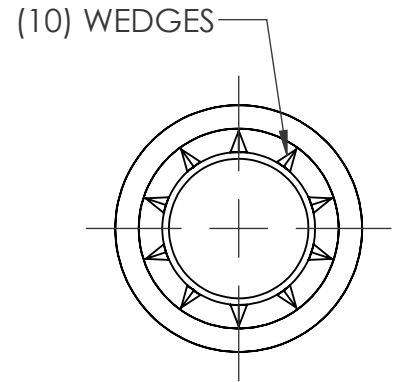
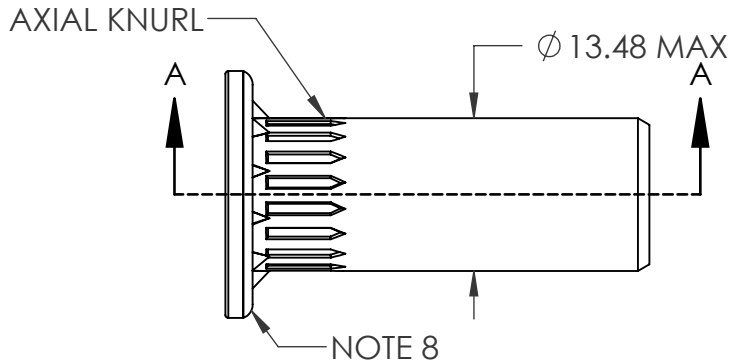
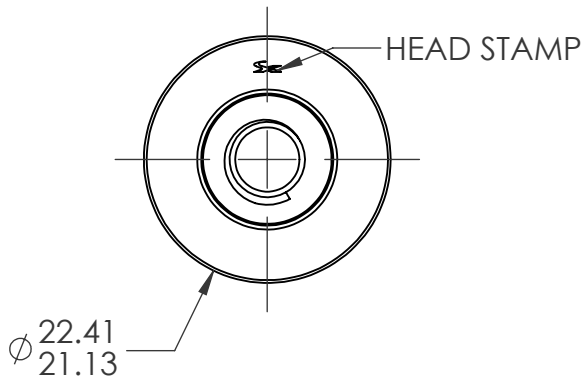

SECTION A-A  
SCALE 1.5 : 1

**NOTE:**

- GRIP RANGE: 1.5 - 3.5
- HOLE SIZE: 13.50 +0.15/-0.00 AFTER ALL APPLIED FINISHES.
- INSTALLED LENGTH: 30.00 MAX
- INSTALLED THREAD DEPTH: 27.0 MIN. IN MIN. GRIP
- LUBRICATION: NONE
- INSTALLATION TOOL: SPIN-PULL
- THREADS MEET CLASS 8 PROOF LOAD: 31.8kN PER ISO 898-2
- DEPOSIT PLASTISOL ALONG OUTER GROOVE OF THE HEAD.

**PROPRIETARY AND CONFIDENTIAL**

THIS DRAWING, AND THE INFORMATION CONTAINED HEREIN, ARE THE PROPERTY OF SHEREX AND ARE NOT TO BE USED IN ANY MANNER DETRIMENTAL TO THE INTEREST OF THE COMPANY.  
SHEREX SOLUTIONS RESERVES THE RIGHT TO REVISE PART/DRAWING WITHOUT NOTICE.

		UNLESS OTHERWISE SPECIFIED:		NAME	DATE
		DIMENSIONS ARE IN MILLIMETERS TOLERANCES: ANGULAR: MACH ± 1 BEND ± 1 ONE PLACE DECIMAL ± 0.3 TWO PLACE DECIMAL ± 0.08	DRAWN	ARG	1/21/21
		INTERPRET GEOMETRIC TOLERANCING PER: ASME Y14.5M-1994	CHECKED		
		MATERIAL C1008/C1010 STEEL	ENG APPR.	CL	1/21/21
		FINISH ZINC PLATE CLEAR TRIVALENT CHROMATE PER SFS-01-001, SC1	MFG APPR.		
NEXT ASSY	USED ON		Q.A.		
APPLICATION		DO NOT SCALE DRAWING	COMMENTS: E-mail: info@sherex.com www.sherex.com Phone: 866-474-3739 Fax: 716-875-0358		

		
SIZE DWG. NO.	REV	
<b>A</b> OPT2-8125-3.5BS	B	
SCALE: 2:1	WEIGHT:	SHEET 1 OF 1