

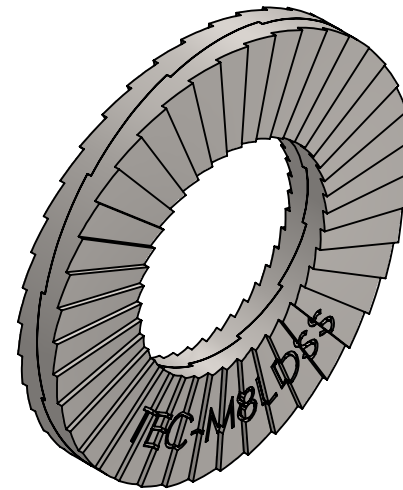

REVISIONS			
REV.	DESCRIPTION	DATE	ECN
A	INITIAL RELEASE	9/6/2018	3089

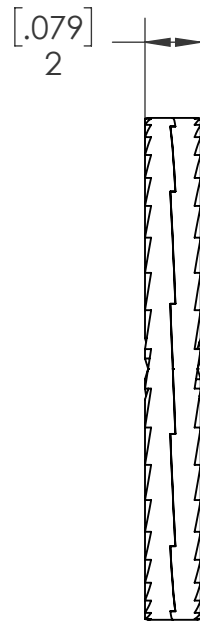
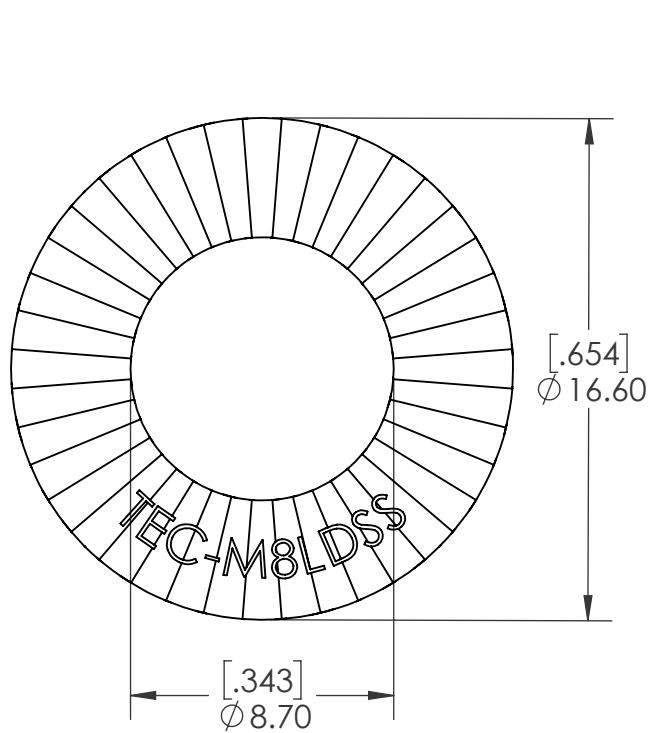

PROPRIETARY AND CONFIDENTIAL
 THIS DRAWING, AND THE INFORMATION CONTAINED HEREIN, ARE THE PROPERTY OF SHEREX AND ARE NOT TO BE USED IN ANY MANNER DETRIMENTAL TO THE INTEREST OF THE COMPANY.
 SHEREX FASTENING SOLUTIONS RESERVES THE RIGHT TO REVISE PART/DRAWING WITHOUT NOTICE.

DRAWING NO.:

UNLESS OTHERWISE SPECIFIED:		NAME	DATE	
DIMENSIONS ARE IN INCHES TOLERANCES: ANGULAR: MACH ± 1 BEND ± 1 I.D. TOLERANCE: $\pm .004$ O.D. TOLERANCE: $\pm .008$ THICKNESS TOLERANCE: $\pm .01$		DRAWN	ARG	
INTERPRET GEOMETRIC TOLERANCING PER: ASME Y14.5M-1994		CHECKED		DESCRIPTION: LARGE DIAMETER TEC WASHER GLUED PAIR 8MM, 5/16"
MATERIAL		ENG APPR.	JVK	
316L STAINLESS STEEL; KOLSTERIZE CASE HARDEN (K22 PROCESS)		MFG APPR.		
FINISH		Q.A.		SIZE PART NO.: A TEC-M8LDSS
NONE		COMMENTS: E-mail: info@disc-lock.com www.disc-lock.com Phone: 866-474-3739 Fax: 716-875-0358		
DO NOT SCALE DRAWING				REV A
		SCALE: 2:1 WEIGHT:		SHEET 1 OF 1