

REVISIONS			
REV.	DESCRIPTION	DATE	ECN
A	INITIAL RELEASE	2/12/2014	1660

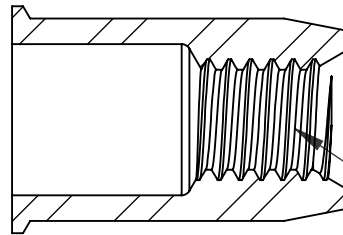

SECTION A-A

M4X0.7 6H
PER ASME B1.13M
MINOR DIA.: 3.24 - 3.42

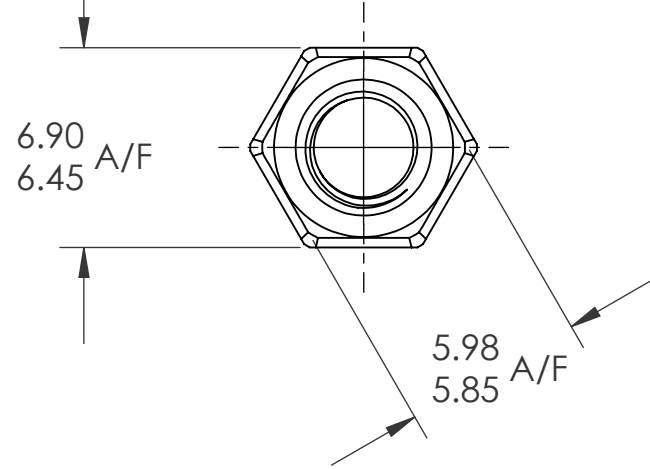
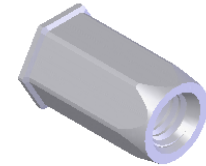

NOTE:

- GRIP RANGE: 0.5-2.0
- HOLE SIZE: 6.0 +0.1/-0.0 A/F AFTER ALL APPLIED FINISHES.
- INSTALLED LENGTH: N/A
- INSTALLED THREAD DEPTH:
- LUBRICATION: NONE
- INSTALLATION TOOL: FLEX 5P/5S SPIN PULL

PROPRIETARY AND CONFIDENTIAL
THIS DRAWING, AND THE INFORMATION CONTAINED HEREIN, ARE THE PROPERTY OF SHEREX AND ARE NOT TO BE USED IN ANY MANNER DETRIMENTAL TO THE INTEREST OF THE COMPANY.
SHEREX SOLUTIONS RESERVES THE RIGHT TO REVISE PART/DRAWING WITHOUT NOTICE.

		UNLESS OTHERWISE SPECIFIED:		NAME	DATE			
		DIMENSIONS ARE IN MILLIMETERS TOLERANCES: ANGULAR: MACH ± 1 BEND ± 1 ONE PLACE DECIMAL ± 0.10 TWO PLACE DECIMAL ± 0.05		DRAWN	JMC		2/12/2014	
		INTERPRET GEOMETRIC TOLERANCING PER: ASME Y14.5M-1994		CHECKED		TITLE:		
		MATERIAL		ENG APPR.	JVK		2/12/2014	
		STEEL DIN QST 34-3		MFG APPR.				
		FINISH		Q.A.	JR	2/12/2014		
		ZINKTOP CLEAR, RoHS COMPLIANT 96W/480R		COMMENTS:		SIZE DWG. NO.		
NEXT ASSY	USED ON			E-mail: info@sherex.com www.sherex.com Phone: 866-474-3739 Fax: 716-875-0358			REV	
APPLICATION		DO NOT SCALE DRAWING				A TU-SM4HUKO20ZT	A	
						SCALE: 2:1	WEIGHT: .0012 kg	SHEET 1 OF 1